

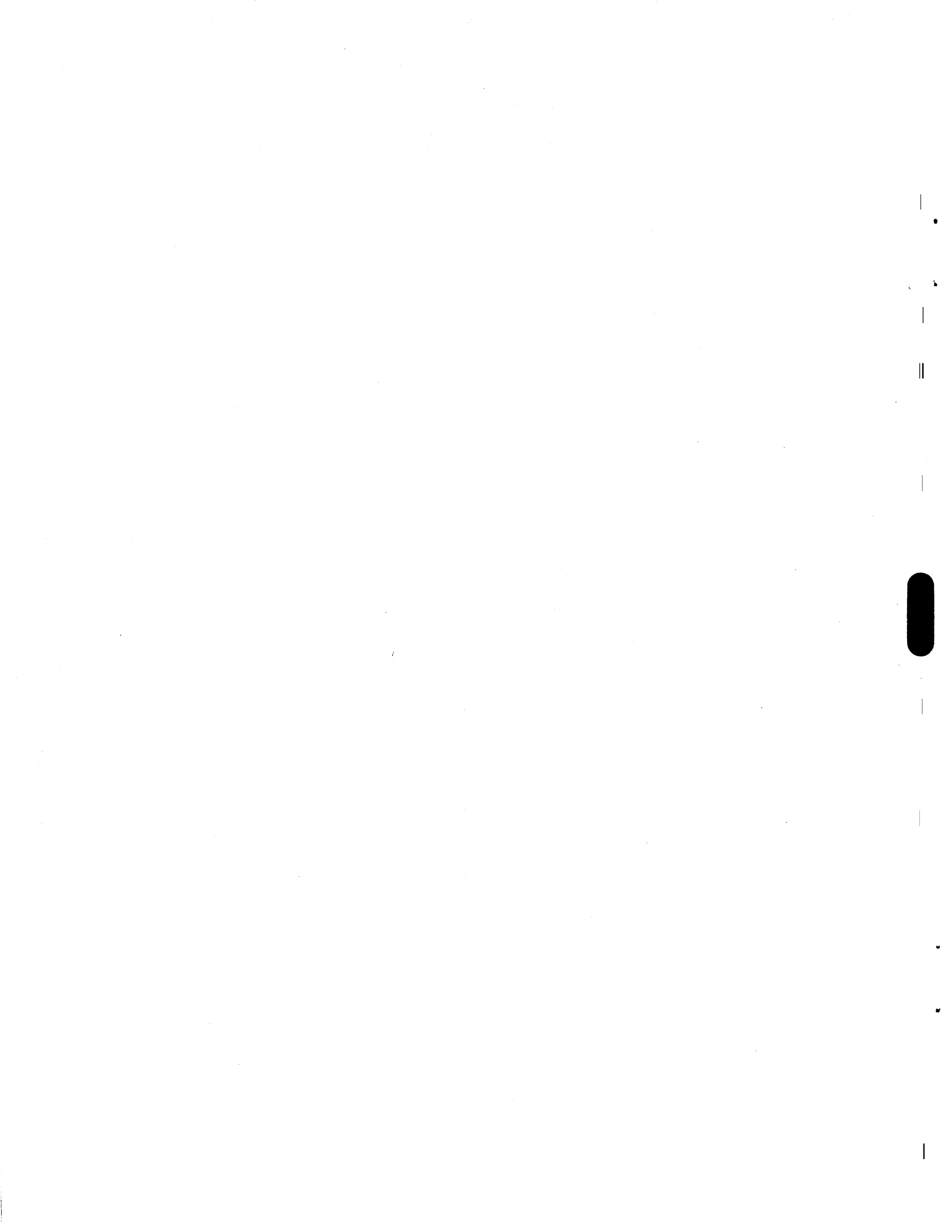

**CDC® KEYBOARD DISPLAY
TERMINAL SUBSYSTEM
CC555, CC628, CW212**

GENERAL DESCRIPTION
OPERATION
INSTALLATION AND CHECKOUT
THEORY OF OPERATION
DIAGRAMS
MAINTENANCE
PARTS DATA

FIELD REPAIR GUIDE





**CDC® KEYBOARD DISPLAY
TERMINAL SUBSYSTEM
CC555, CC628, CW212**

GENERAL DESCRIPTION
OPERATION
INSTALLATION AND CHECKOUT
THEORY OF OPERATION
DIAGRAMS
MAINTENANCE
PARTS DATA

FIELD REPAIR GUIDE

MANUAL TO EQUIPMENT LEVEL CORRELATION SHEET

This manual reflects the equipment configurations listed below.

EXPLANATION: Locate the equipment type and series number, as shown on the equipment FCO log, in the list below. Immediately to the right of the series number is an FCO number. If that number and all of the numbers underneath it match all of the numbers on the equipment FCO log, then this manual accurately reflects the equipment.

EQUIPMENT TYPE	SERIES	WITH FCOs	COMMENTS
CC555-A	02	12626	
CC628-A	01		
CC628-B	01		
CW212-A	02	14242	

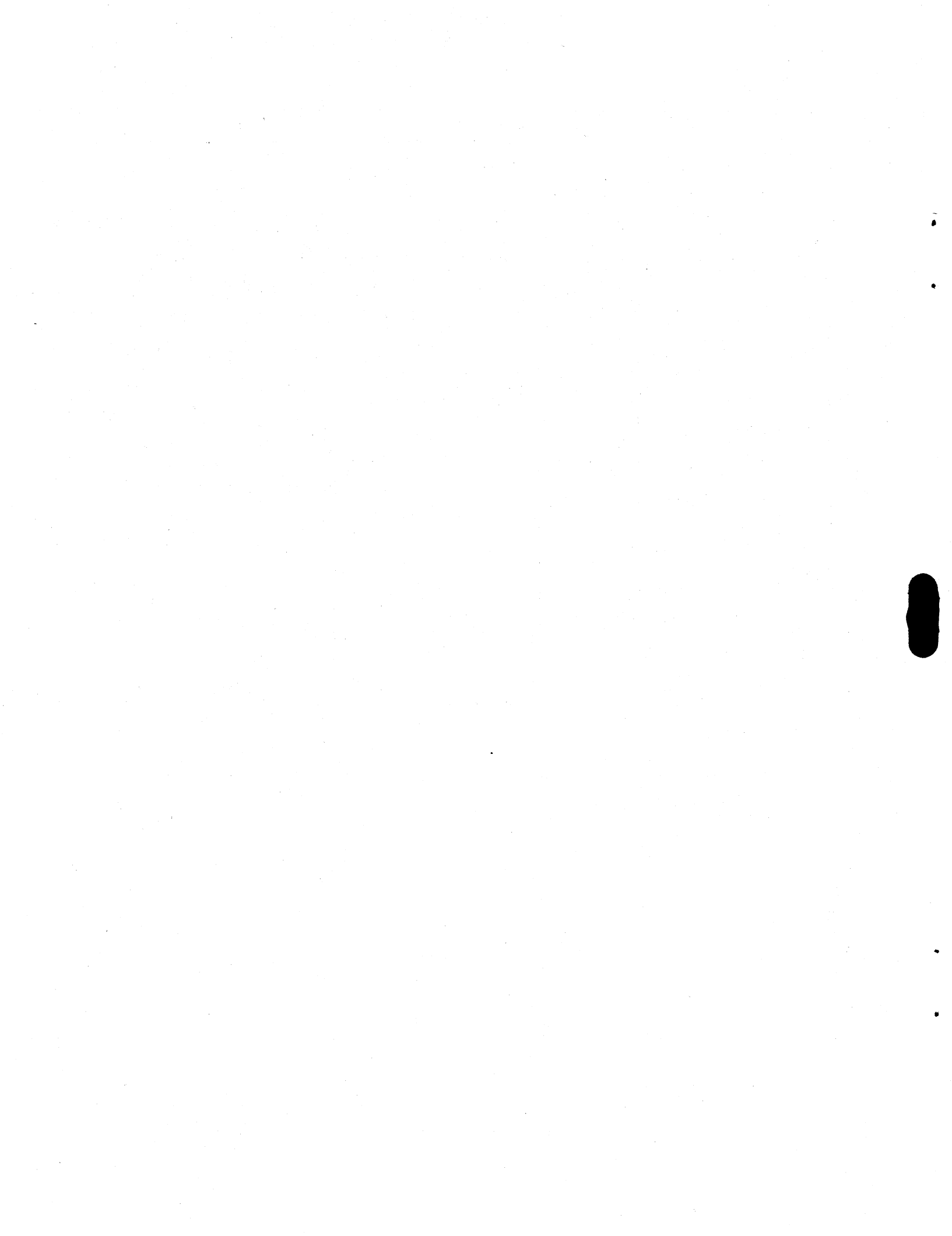

LIST OF EFFECTIVE PAGES

New features, as well as changes, deletions, and additions to information in this manual, are indicated by bars in the margins or by a dot near the page number if the entire page is affected. A bar by the page number indicates pagination rather than content has changed.

PAGE	REV	PAGE	REV	PAGE	REV	PAGE	REV	PAGE	REV
Cover	--								
Title Page	--								
ii	D								
iii/iv	D								
v/vi	D								
vii/viii	D								
ix/x	B								
1-1	B								
1-2	B								
2-1	B								
2-2	B								
2-3 thru 2-9	B								
3-1	A								
4-1 thru 4-6	B								
5-1	B								
5-2	B								
5-3	A								
5-4	A								
6-1	A								
6-2	B								
6-3	B								
6-4	C								
6-5 thru 6-17	B								
7-1	D								
Comment Sheet	D								
Cover	--								

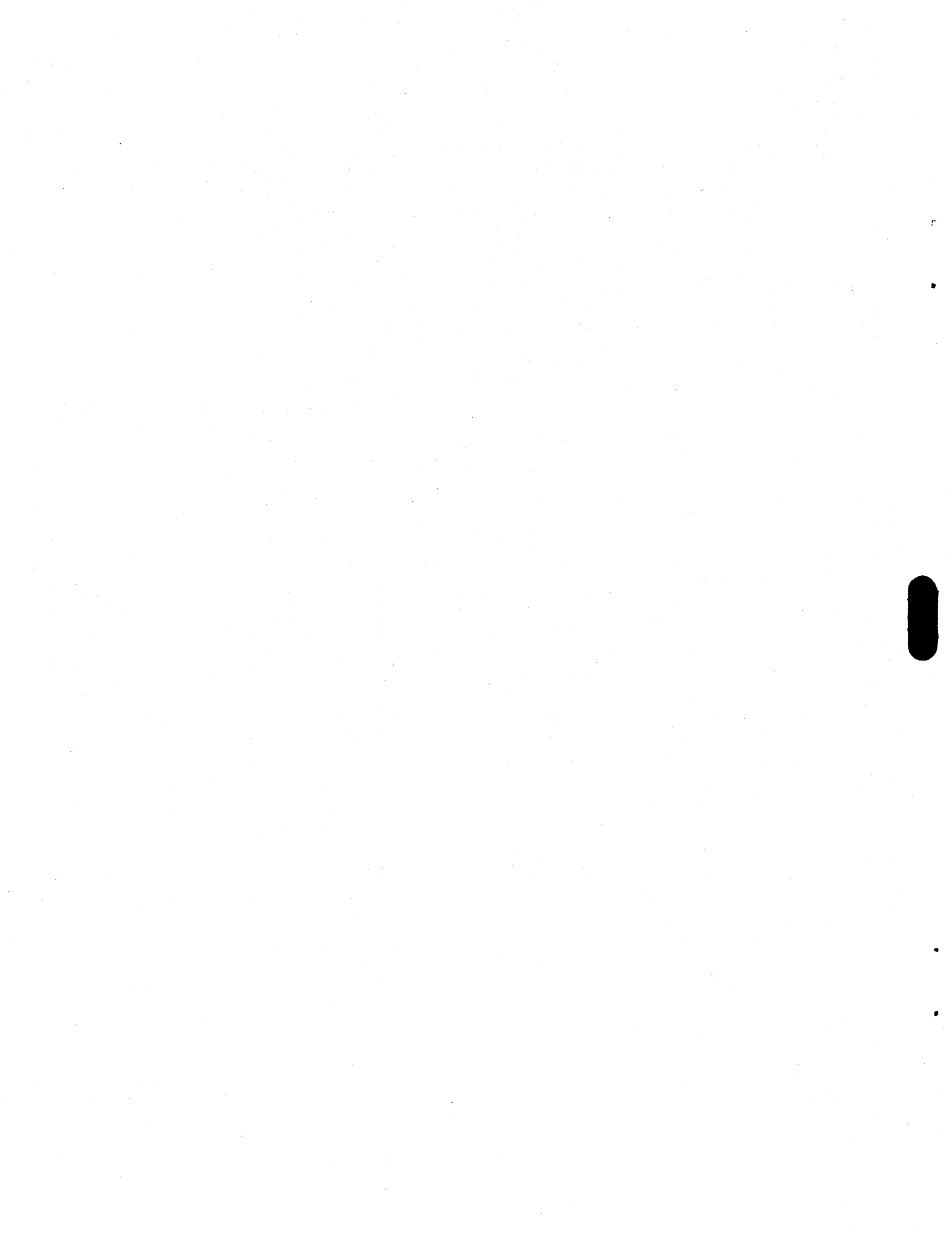

PREFACE

This manual provides maintenance information for the Control Data® CYBER 18 Keyboard Display Terminal Subsystem. The information contained herein supports maintenance of the keyboard display terminal subsystem when it is incorporated in the CYBER 18 systems. The subsystem includes the CC555 or CC628 Keyboard Display Terminal and the CW212 I/O-TTY Controller.

This publication contains information to aid maintenance personnel in carrying out onsite maintenance tasks. The maintenance approach is to fault isolate using the

diagnostic decision logic tables (DDLTs) and to make repairs by using the removal/replacement procedures. Corrective action is accomplished by exchanging replaceable subassemblies rather than components. When repair cannot be accomplished by exchanging replaceable subassemblies, a support customer engineer is required.

The publications listed below provide more detailed information relative to equipments, systems, and subsystems.

<u>Publication</u>	<u>Publication Number</u>
722-10 (CC628) Display Terminal Hardware Maintenance Manual	62940003
722-10 (CC628) Display Terminal Operators Guide/ Installation Instructions	62940002
722-10 (CC628) Display Terminal Reference Manual	62940001
752 (CC555) Keyboard Display Terminal Hardware Maintenance Manual	62957400
752 (CC555) Keyboard Display Terminal Operators Guide/Reference Manual	62957300
AA132, AA133, AA153, DT120, FC402 CYBER 18 Computer Systems Central Processor Field Repair Guide	60475001
Basic Micro-Programmable Processor Hardware Reference/Maintenance Manual	39451400
CYBER 18 Computer Systems Overview Manual	60475000
CYBER 18 Computer Systems with MOS Memory Installation Manual	96768360
Operational Diagnostic Systems (ODS) Version 2 Reference Manual	96768410



CONTENTS

1.	GENERAL DESCRIPTION	1-1	Baud Rate Switches	4-3
			Special Functional Switches	4-3
2.	OPERATION	2-1	CC628 Switch/Jumper Settings, Normal Operation	4-3
			I/O-TTY Controller	4-3
			Internal Controls	4-3
			External Controls	4-3
3.	INSTALLATION AND CHECKOUT	3-1		
4.	THEORY OF OPERATION	4-1	5. DIAGRAMS	5-1
	CC555 Replaceable Assemblies	4-1		
	I/O-TTY Controller Logic	4-1	6. MAINTENANCE	6-1
	Control Logic PWA	4-1	Maintenance Aids	6-1
	Cathode Ray Tube (CRT)	4-1	Maintenance Equipment Required	6-1
	High-Voltage Transformer	4-1	Description or Diagnostic Decision Logic Tables	6-1
	+15-Volt Regulator	4-1	Assumptions	6-1
	Deflection Yoke	4-1	Conditions	6-1
	Monitor PWA	4-1	Responses	6-1
	Rear Panel Assembly	4-1	Actions	6-1
	Power Supply PWA	4-2	Sequence of Actions	6-1
	Video Monitor Assembly	4-2	User Notes	6-3
	Vertical Choke Coil	4-2	ODS Software	6-3
	Keyboard Module	4-2	Diagnostic Decision Logic Table	6-4
	Intensity Control Potentiometer	4-2	Procedures	6-17
	Power Supply Assembly	4-2		
	Audible Alarm (SONALERT)	4-2	7. PARTS DATA	7-1
	CC555 Switch/Jumper Settings, Normal Operation	4-3		
	I/O-TTY Board (Logic)	4-3		
	Control Switches (Internal)	4-3		

FIGURES

1-1	CC555 Keyboard Display Terminal Physical Characteristics	1-1	4-3	CC628 External Controls, Operator Access Door	4-5
1-2	CC628 Keyboard Display Terminal	1-2	4-4	CC628 Power ON/OFF Switch and Keyboard Indicators	4-6
2-1	CC555 Keyboard Display Terminal Front Panel Switches and Indicators	2-1	4-5	CC628 Display Terminal (Bottom View)	4-6
2-2	CC555 Keyboard Display Terminal Rear Panel	2-2	5-1	CC555 Signal Interconnect Diagram	5-2
2-3	CC628 Display Terminal External Operator Controls and Indicators	2-3	5-2	Ac/Dc Power Interconnect Diagram	5-3
2-4	CC628 Display Terminal (Bottom View)	2-4	5-3	Keyboard Display to I/O-TTY Controller Interface Cable	5-4
2-5	CC628 Keyboard Key Layout	2-4	5-4	CYBER 18 Cable - Keyboard Display to Panel Multiplexer	5-4
4-1	CC555 Keyboard Display Terminal Subassemblies	4-2	6-1	Example of a Diagnostic Decision Logic Table	6-2
4-2	CC555 Keyboard Display Internal Switches and Controls	4-4			

TABLES

2-1	CC555 Keyboard Display Terminal Controls and Indicators	2-2	4-1	Replaceable Assemblies	4-1
2-2	CC628 Display Terminal External Operator Controls and Indicators	2-5	6-1	LIAT1: Keyboard Display Terminal Diagnostic DDLT	6-4
2-3	CC555/CC628 Keycode Correlation	2-9	7-1	Parts Data for Keyboard Display Terminal	7-1



GENERAL DESCRIPTION

The keyboard display terminal may be a CC555 (figure 1-1) or a CC628 (figure 1-2). It is a remote communication device that operates in a conversational mode with the central processor at speeds of 110 to 9600 baud. It functions as a remote input/output device.

including an asynchronous bit-serial, byte-serial, communication facility interface to permit the terminal to operate in conversational mode in the same manner as a teletypewriter unit.

The keyboard display terminal performs input and terminal control functions via keyboard assembly and monitors both input and output functions on a 12-inch (305-millimeter) cathode ray tube (CRT) display screen. Included within the terminal are all of the necessary electronics,

The terminal can display 24 lines of 80 characters per line (1920-character display) and features a 95-character alphanumeric keyboard including control functions and numeric pad, transmission of a character at a time, half-duplex mode, scroll mode, and local offline test mode.

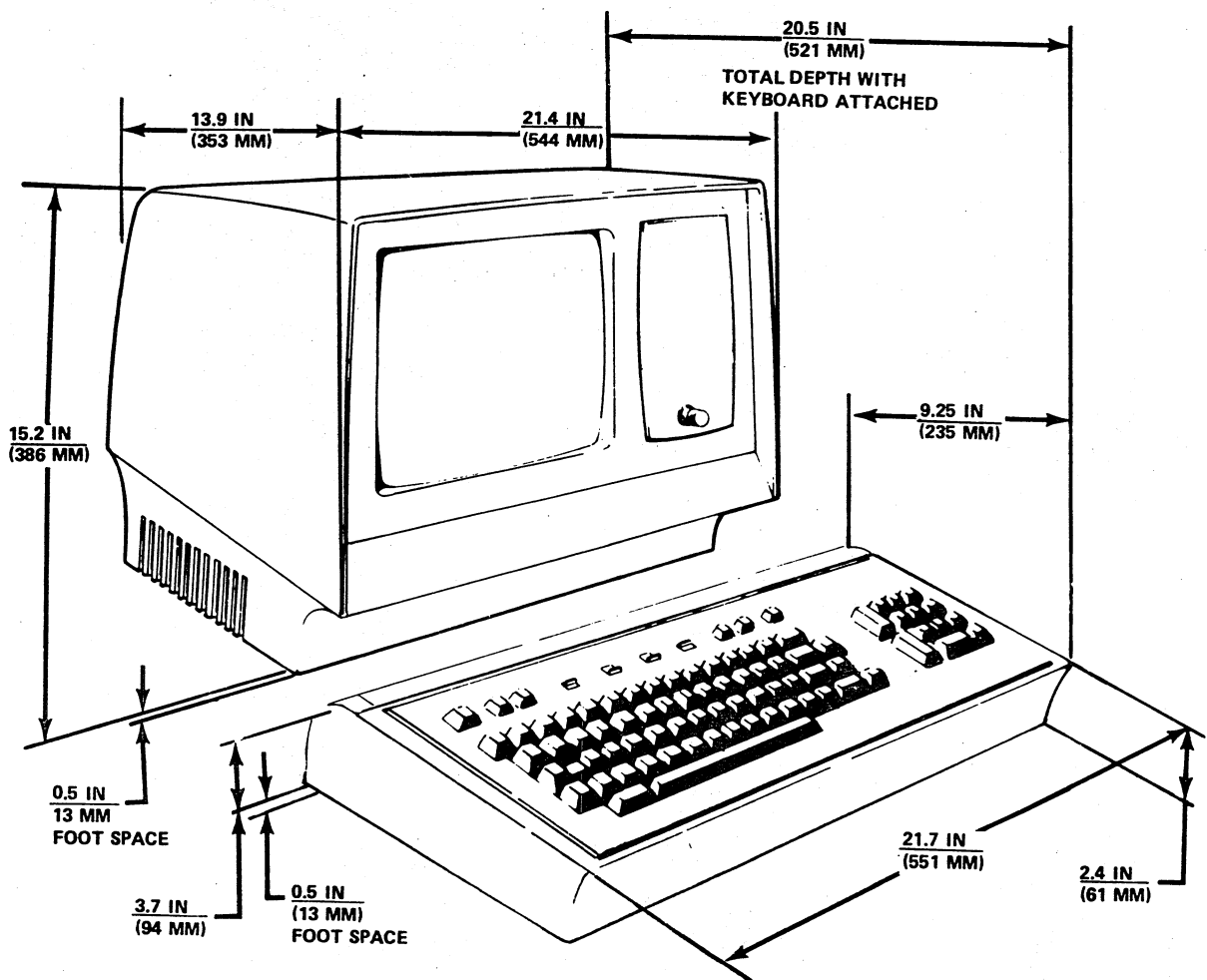

1198

Figure 1-1. CC555 Keyboard Display Terminal Physical Characteristics

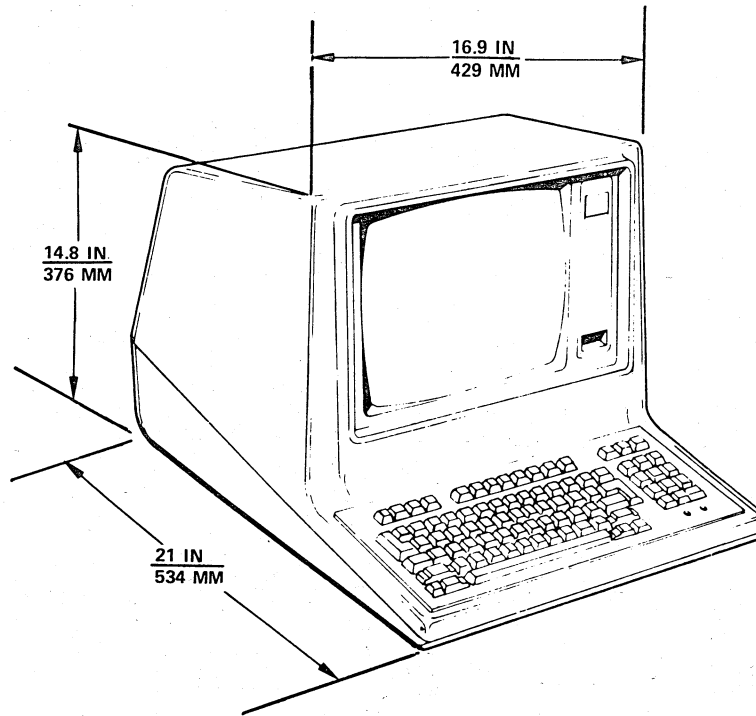

2412

Figure 1-2. CC628 Keyboard Display Terminal

This section contains descriptions of the operator controls and indicators contained on the keyboard display terminal equipment.

Figure 2-1 shows the location of the control switches and indicators on the front panel of the CC555 keyboard display terminal, and figure 2-2 shows the location of the control switches on the rear panel of the terminal. Table 2-1 describes the controls and indicators located on the front and rear panels of the terminal. Figure 2-3 shows the location of the keyboard indicators, power ON/OFF

switch, and external operator controls of the CC628 display terminal. Figure 2-4 shows the operator controls on the base of the CC628 display terminal. Figure 2-5 shows the keyboard key layout of the CC628 display terminal. Table 2-2 describes the functions of the CC628 external operator controls and indicators.

CC555 terminal keyboards contain key codes which are not found on CC628 terminal keyboards. Table 2-3 shows how to generate CC555 key codes using a CC628 terminal.

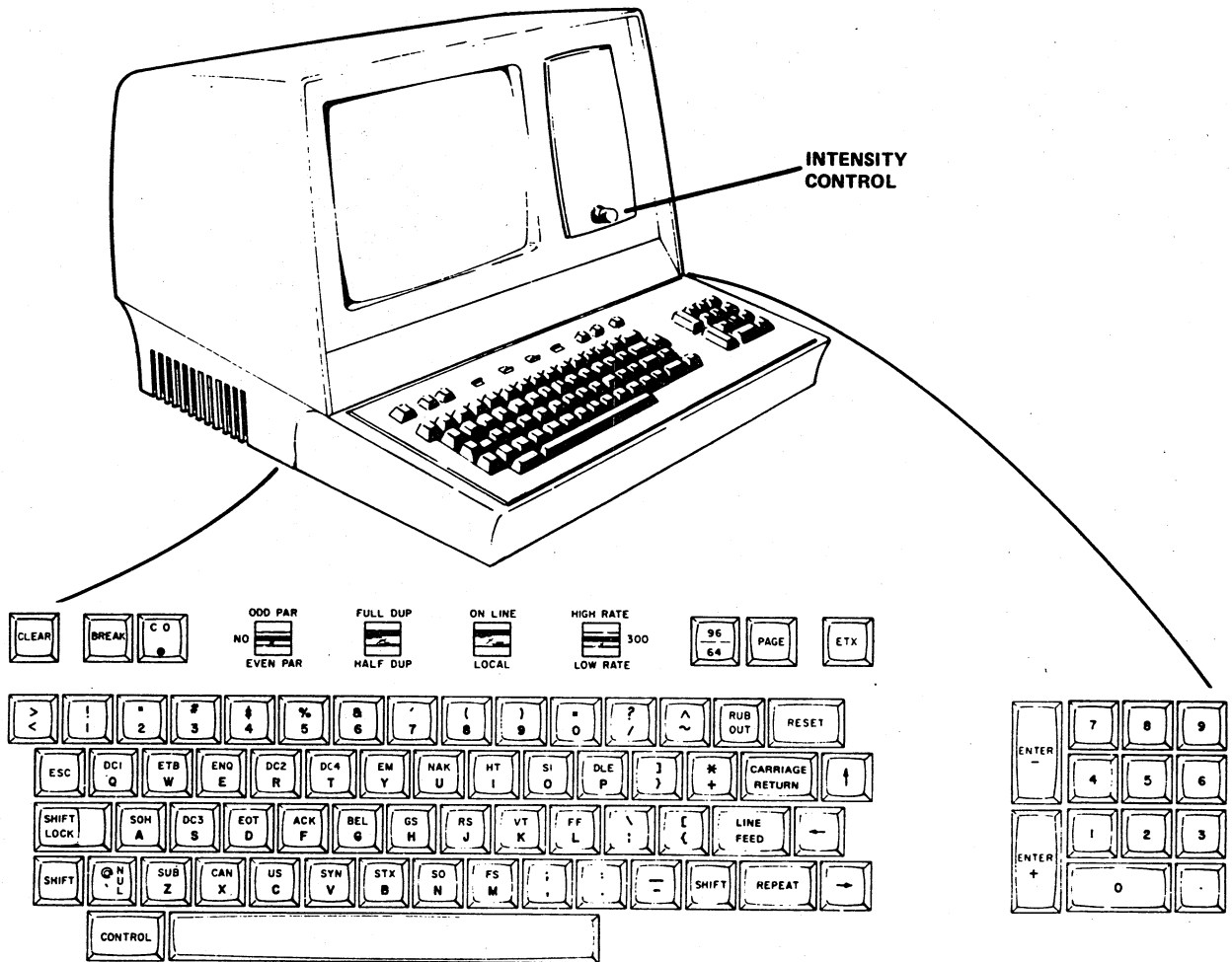

1199

Figure 2-1. CC555 Keyboard Display Terminal Front Panel Switches and Indicators

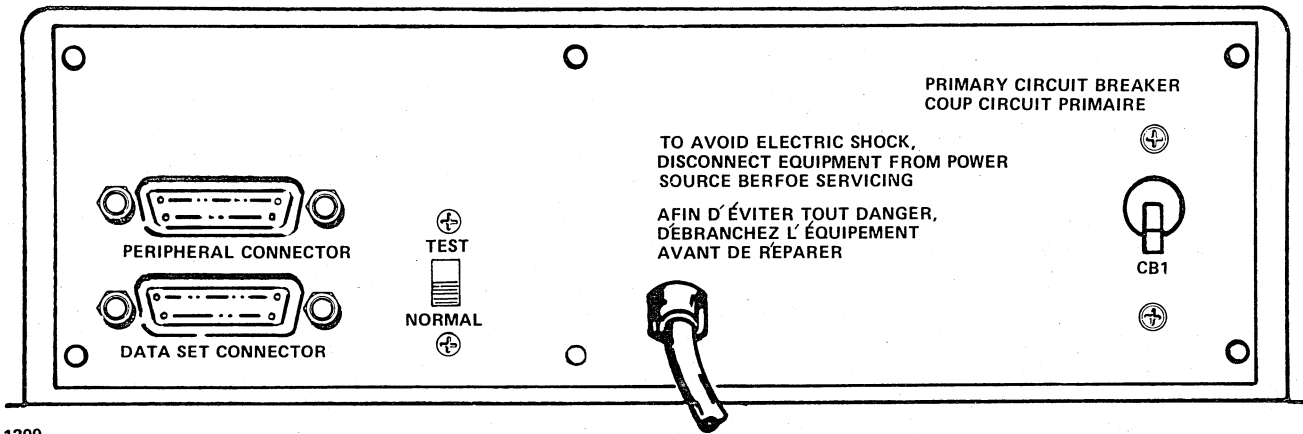

Figure 2-2. CC555 Keyboard Display Terminal Rear Panel

TABLE 2-1. CC555 KEYBOARD DISPLAY TERMINAL CONTROLS AND INDICATORS

Controls and Indicators	Type	Location	Function
ON LINE/LOCAL	Toggle switch	Front panel	In the ON LINE position, connects the modem interface circuitry to the keyboard, memory, and display circuitry of the terminal. The LOCAL position disconnects the modem interface circuitry and allows information typed on the keyboard to be displayed.
FULL DUP/ HALF DUP	Toggle switch	Front panel	Selects whether the terminal transmits and receives serial data in the full- or half-duplex mode.
CO	Pushbutton/ indicator	Upper row of keys	Carrier on. Indicates that the communication interface (modem) is ready to receive data from an external device.
INTENSITY	Potentiometer	Front panel	Rotating this control changes the video intensity of data displayed on the screen.
TEST/NORMAL	Slide switch	Rear panel	Selects either the test or normal operating mode of the terminal.
CB1	Toggle switch	Rear panel	This switch (circuit breaker) trips automatically if excessive power is drawn by the terminal.
Audible alarm	Indicator (audible)	Internal	Sounds to indicate proximity to the end of a line when keyboard data is being entered.
HIGH RATE/300/ LOW RATE	Toggle switch	Front panel	A three-position switch that selects baud rates, internally preselected for high and low rates. In the center position, the terminal operating rate is fixed at 300 baud. For batch terminal applications, the high and low rates are set to 9600 baud.

TABLE 2-1. CC555 KEYBOARD DISPLAY TERMINAL CONTROLS AND INDICATORS (Contd)

Controls and Indicators	Type	Location	Function
ODD PAR/NO/ EVEN PAR	Toggle switch	Front panel	Selects terminal odd or even parity operation. Should be set to the EVEN PAR position for batch terminal applications.
64 CHAR/ 96 CHAR	Pushbutton	Upper row of keys	Selects only uppercase characters to be displayed when set to the 64 CHAR position. The 96 CHAR position allows the display of both uppercase and lowercase characters. Should be set to the 64 CHAR position for batch terminal applications.
PAGE	Pushbutton	Upper row of keys	Selects page mode or scroll mode of operation. In the down position, page mode operation is selected. In the up position, scroll mode operation is selected.

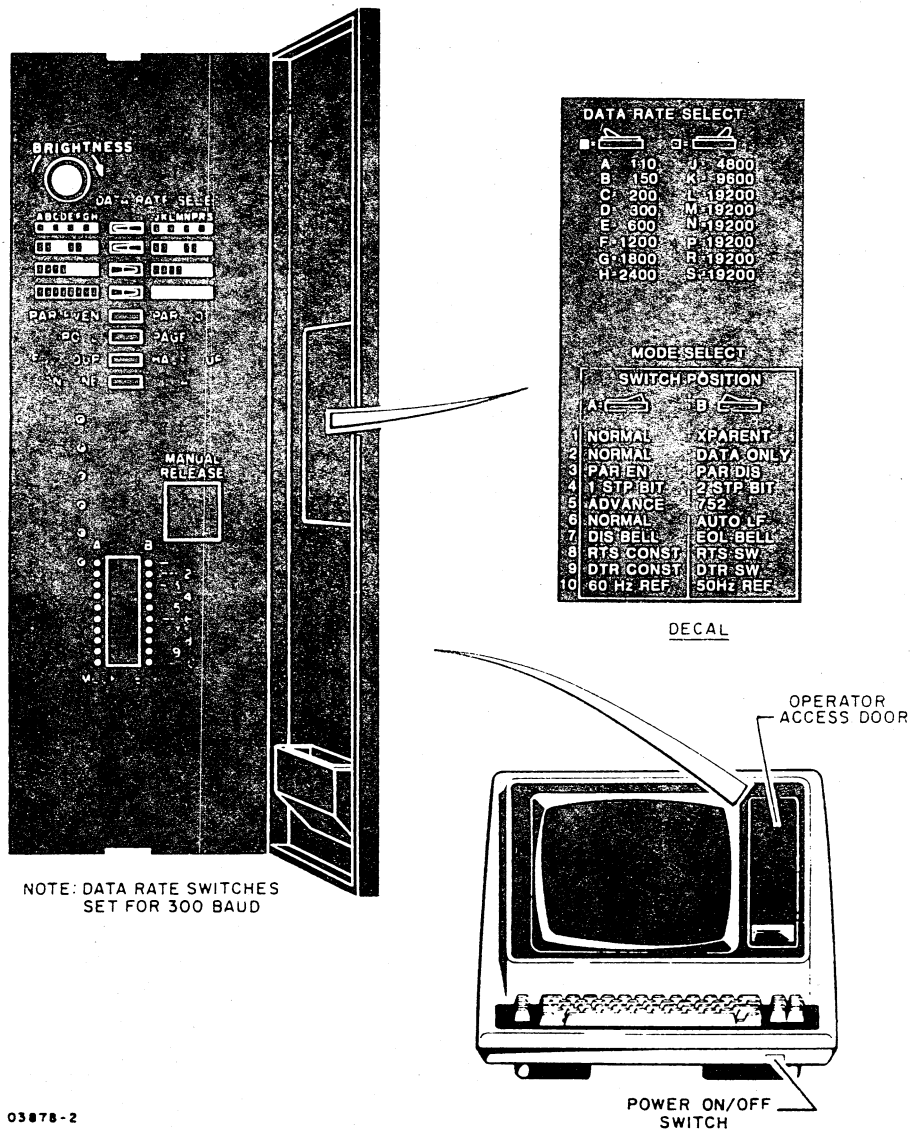
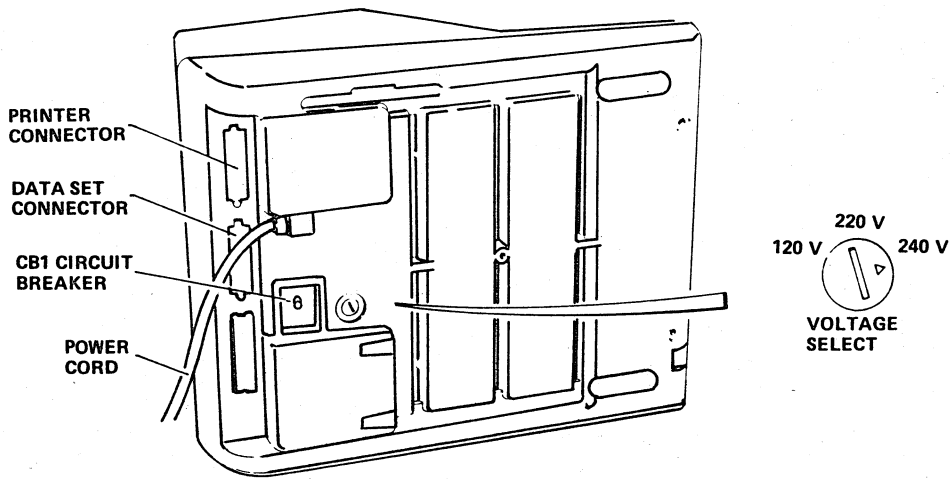

Figure 2-3. CC628 Display Terminal External Operator Controls and Indicators



2418

Figure 2-4. CC628 Display Terminal (Bottom View)

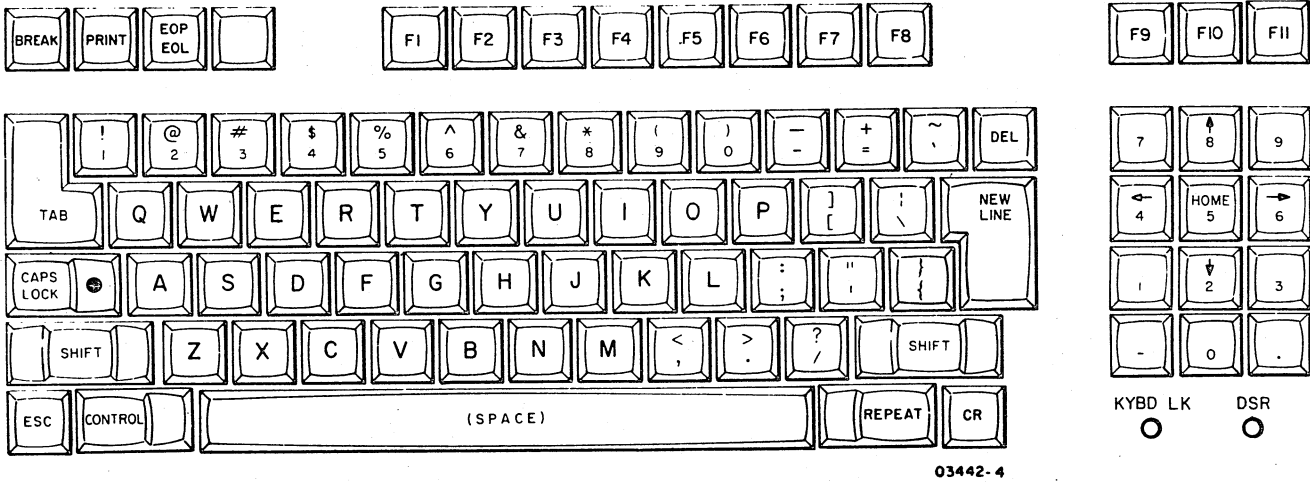

Figure 2-5. CC628 Keyboard Key Layout

TABLE 2-2. CC628 DISPLAY TERMINAL EXTERNAL OPERATOR CONTROLS AND INDICATORS

Designation	Type	Function								
TERMINAL BASE										
CBI	Pushbutton circuit breaker	Provides overload protection for the display terminal.								
VOLTAGE SELECT	Rotary switch	Three-position switch that selects the voltage tap of the power transformer compatible with the site ac power source. <table style="margin-left: auto; margin-right: auto;"> <tr> <td>Setting</td> <td>Power source</td> </tr> <tr> <td>120 V</td> <td>104 V to 128 V</td> </tr> <tr> <td>220 V</td> <td>191 V to 235 V</td> </tr> <tr> <td>240 V</td> <td>208 V to 256 V</td> </tr> </table>	Setting	Power source	120 V	104 V to 128 V	220 V	191 V to 235 V	240 V	208 V to 256 V
Setting	Power source									
120 V	104 V to 128 V									
220 V	191 V to 235 V									
240 V	208 V to 256 V									
POWER ON/OFF	Slide switch	Controls application of ac power to enable terminal operation. When slider is extended (red-orange stripe is visible), power is on. When slider is flush, power is off.								
OPERATOR ACCESS DOOR										
BRIGHTNESS	Potentiometer	Provides the operator with adjustment of display character intensity to ambient lighting conditions.								
DATA RATE SELECT	Toggle switch	Selects one of eleven data switch transfer (baud) rates. Refer to decal on inside of access door and set conditions (light and dark blocks) illustrated in figure 2-3. Setting is accomplished by following the alphabetical block coding vertically through the four switches immediately below each letter. (Set each switch to the right for a light block and to the left for a dark block.)								
PAR EVEN/ PAR ODD	Toggle switch	Selects even or odd parity generation for transmitted character and test of received characters.								
ROLL/PAGE	Toggle switch	Selects scroll or page mode operation (ROLL = scroll). Effective only when terminal is operating in the 752 scheme. (Should be in ROLL position.)								
FULL DUP/ HALF DUP	Toggle switch	Alters routing of keyboard data within the terminal. In FULL DUP position with terminal online, keyed-in data is transmitted to the controller and displayed data is received from the controller (echo mode). In HALF DUP position with terminal online, keyed-in data is transmitted to the controller and terminal memory for display.								
ON LINE/ LOCAL	Toggle switch	In ON LINE position the terminal is enabled for online communication; communication interface is subject to conditioning by the keyboard and performance controls. In LOCAL position, the terminal transfers keyed-in data to the display screen and to the printer interface, but does not route it to the transmit interface.								
MANUAL RELEASE	Pushbutton	Enables terminal reinitialization, terminates a print operation, unlocks the keyboard, and initiates transparent mode test if TRANSPARENT mode was selected. Displayed data is unaffected.								
MODE SELECT	10-position DIP switch	Selects the operating modes described below. If A side is down, the associated A mode (listed on decal) is selected. If B side is down the associated B mode is selected. These switches are used primarily for terminal checkout.								

TABLE 2-2. CC628 DISPLAY TERMINAL EXTERNAL OPERATOR CONTROLS AND INDICATORS (Contd)

Designation	Type	Function
NORMAL/ TRANSPARENT	Rocker switch	In NORMAL position the terminal functions as an online TRANSPARENT communication link with a controller. In TRANSPARENT position any data entry enabled results in the display of the octal code associated with the selection.
NORMAL/DATA ONLY	Rocker switch	In NORMAL position the terminal inhibits transmitted data and DATA ignores received data if DSR and DTR are off. If RTS SWITCHED is selected the received line signal detector must also be on to receive data. In DATA ONLY position, the terminal ignores RS232 modem control signals. Data is transmitted regardless of RTS or CTS.
PARITY ENABLE/ PARITY DISABLE	Rocker switch	In PARITY ENABLE position, the terminal tests or generates word parity in accord with the PAR EVEN, PAR ODD switch setting. In PARITY DISABLE position, the parity logic is DISABLE disabled, causing a mark or space condition in the parity bit position of the transmitted word (if PAR EVEN, a mark; if PAR ODD, a space).
STOP BIT/ STOP BITS	Rocker switch	In STOP BIT position, one stop bit is inserted in the transmitted word. In STOP BITS position, two stop bits are inserted in the transmitted word.
ADV/752	Rocker switch	Permits choice of communication line coding, either in advanced or 752 mode.
NORMAL/ AUTO LF	Rocker switch	Only applicable to 752 mode of operation. In NORMAL position a CR key operation positions the cursor to the beginning of the current line. In AUTO LF position a CR key operation positions the cursor to the beginning of next line.
DISABLE BELL/ EOL BELL	Rocker switch	Affects operation of audible alarm (bell). In DISABLE BELL position the audible alarm is disabled. In EOL BELL position the audible alarm sounds when the cursor moves from character 72 to 73 or advances from line 23 to 24.
RTS CONSTANT/ RTS SWITCHED	Rocker switch	Affects the response of the RTS (request to send) signal. In RTS CONSTANT position the RTS signal is on whenever DSR and DTR are on. If the switch is in RTS SWITCHED position with DSR and DTR on and the NORMAL/DATA ONLY switch in NORMAL position, then RTS operates as follows: <ul style="list-style-type: none"> ● HALF DUP selected - RTS is on with first key stroke and switched off 1.0 millisecond following transmission of CR, ETX, EOT, or LF; or a break code or local mode is selected. Automatic sequences cause RTS to be on for duration of response and switched off 1.0 millisecond after the last word transferred. ● FULL DUP selected - RTS is on when power is applied and switched off if ON LINE/LOCAL switch is set to LOCAL.
DTR CONSTANT/ DTR SWITCHED	Rocker switch	Affects the condition of the DTR (data terminal ready) signal. In DTR CONSTANT position, the DTR signal to the modem is held on at all times. In DTR SWITCHED position the DTR signal is off if the ON LINE/LOCAL switch is in LOCAL position, otherwise DTR signal is on. Received data is ignored when DTR signal is off.
60 HZ REFRESH/ 50 HZ REFRESH	Rocker switch	Selects the terminal memory refresh rate. Refresh rate must be compatible with primary power frequency. If refresh rate is reset, reinitialize terminal by powering it on and off.

TABLE 2-2. CC628 DISPLAY TERMINAL EXTERNAL OPERATOR CONTROLS AND INDICATORS (Contd)

Designation	Type	Function
KEYBOARD		
KYBD LK	LED indicator	The keyboard lock (KYBD LK) indicator lights during page print operations or if terminal is unable to transmit data due to loss of modem control signals while terminal is online and ready to send.
DSR	LED indicator	The DSR (data set ready) indicator lights when DSR signal is active. Data is not transmitted and the received data line is not monitored if DSR is off.
DATA ENTRY AND CONTROL	Keys	Provide operator entry of specific symbol and control codes that are displayed and/or transmitted as directed by the performance control switches. The keyboard can generate all 128 ASCII codes plus 46 code sequences that are enabled by special function keys. The keyboard is a four level device that operates as follows: <ul style="list-style-type: none"> ● Lower case mode - SHIFT or CONTROL key not pressed ● Upper case mode - SHIFT key pressed ● Control mode - CONTROL key pressed ● Control mode - SHIFT and CONTROL keys both pressed
SHIFT	Key	Enables access to uppercase characters and symbols indicated on key caps. Shift function is active only while SHIFT key is held down.
CAPS LOCK	Key/LED indicator	Alternate action key that locks and unlocks each time it is pressed. When locked the indicator lights and the keys are locked in uppercase mode. Special symbol, function, and numeric keys are unaffected.
CONTROL	Key	Pressing the CONTROL key in conjunction with any data entry key or combination of data entry and SHIFT keys enable the control mode codes.
ESC	Key	Escape key. Changes CYBER 18 operation from program mode to panel mode when 752 mode is selected.
DEL	Key	Delete key. Deletes the character above the cursor and transmits the deletion code to the controller.
EOP/EOL	Key	End of page/end of line key. Unshifted activation of this key clears the current line and places space codes in each memory location affected. Shifted activation of this key clears the entire display screen, places space codes in the memory location affected, and resets the cursor to home position.
BREAK	Key	Forces the transmitted data signal to spacing condition and the secondary RTS line to off condition for approximately 250 milliseconds.
REPEAT	Key	Permits the selected character or symbol to be generated repeatedly as long as the REPEAT key is held down. Press the REPEAT key then the data entry key. After the repeat has been enabled, the data-entry key may be released.

TABLE 2-2. CC628 DISPLAY TERMINAL EXTERNAL OPERATOR CONTROLS AND INDICATORS (Contd)

Designation	Type	Function
PRINT	Key	Has no affect when terminal is operating in 752 mode. In ADV mode, enables the transfer of data to the printer from beginning of the current line to the end of the page; line drawing codes are replaced with spaces and CR/LF is inserted at the start of the page and the end of every line. If pressed in conjunction with the SHIFT key, all reduced-intensity data is also replaced by spaces.
CR	Key	Carriage return. In 752 mode with AUTO LF selected, pressing CR resets the cursor to the beginning of the next line. In ADV mode, pressing CR resets the cursor to the beginning of the current line.
TAB	Key	Places an ASCII HT code (011 ₈) on the transmit data line during online operation.
NEW LINE	Key	In 752 mode performs the same function as CR. In ADV mode, the cursor is reset to the first character of the next line.
Cursor control	Keys	Move cursor up ↑, down ↓, backspace ←, skip →, and HOME. These keys are active when pressed in conjunction with the SHIFT key. HOME is dependent upon the selected operating mode, ADV or 752. HOME position is the first character position in the first line of the display screen, unless operating in 752 and roll modes. Then, HOME position is the first character position in the last line of the display screen.
Numbers 1 thru 10	Keys	Insert numbers 1 through 10 and provide rapid number insertion capability.
Functions F1 thru F11	Keys	Generate a specific octal code sequence that is unique to each key, whether it is used unshifted or in conjunction with the SHIFT or CONTROL key. The functions performed by these keys are determined by the system application.

TABLE 2-3. CC555/CC628 KEYCODE CORRELATION

CODE	PRESS CONTROL AND	1811 FUNCTION
ACK	F	
BEL	G	BELL
BS	H	BACKSPACE
CAN	X	CLEAR
CR†	M	CARRIAGE RETURN
DC1	Q	
DC2	R	
DC3	S	
DC4	T	
DEL†	DEL	RUBOUT
DLE	P	
EM	Y	RESET
ENQ	E	
EOT	D	
ESC†	ESC	
ETB	W	
ETX	C	SEND
FF	L	
FS	/	ENTER -
GS	[ENTER +
HT†	I	TAB
NAK	U	
NL ††	J	NEW LINE
NUL	2 (@/2)	
RS	=	
SI	O	
SO	N	
SOH	A	
STX	B	
SUB	Z	
SYN	V	
US	-	
VT	K	

†Special keys are available for the CR (carriage return), ESC (escape), DEL (Rubout) and HT (tab) functions. If the special keys are used, do not use the control key.

††The NEW LINE and CR keys are functionally the same, both cause the cursor to return. The line feed is handled by CYBER 18 software. Additional lines may be fed by pressing shift and ↓.



Refer to the installation manual listed in the preface for information applicable to installing the keyboard display terminal subsystem. Detailed instructions on the initial

system installation or on adding new equipment to the system may be found in that manual.



This section contains a list of replaceable assemblies for the keyboard display terminal subsystem and a brief description of each replaceable assembly. Part numbers for replaceable assemblies may be found in section 7.

Illustrations of switch and jumper locations on the printed wiring assemblies are provided in this section. Tables are also included that list the switch settings and jumper connections for normal operation.

CC555 REPLACEABLE ASSEMBLIES †

Table 4-1 lists the replaceable assemblies of the CC555 keyboard display terminal subsystem. See section 7 for assembly and miscellaneous part numbers.

TABLE 4-1. REPLACEABLE ASSEMBLIES

Replaceable Assembly	Assembly Type
I/O-TTY controller	Printed wiring assembly
Control logic	Printed wiring assembly
Cathode ray tube	Unit
High-voltage transformer	Unit
15 V regulator	Unit
Deflection yoke	Unit
Monitor board	Printed wiring assembly
Rear panel assembly	Unit
Power supply board	Printed wiring assembly
Test/normal switch	Unit
Vertical choke coil	Unit
Keyboard module	Unit
Intensity control potentiometer	Unit
Power supply assembly	Unit
Audible alarm	Unit

The following is a brief description of the replaceable assemblies of the keyboard display terminal. For additional details refer to the keyboard display hardware maintenance manual. See figure 4-1 for the location of the following assemblies within the keyboard display terminal.

I/O-TTY CONTROLLER LOGIC

This logic, located in the processor chassis, provides signal interface control between the processor and the terminal.

CONTROL LOGIC PWA

This PWA contains the bulk of the electronics for the keyboard display terminal. It contains the horizontal and vertical control circuitry, character generator, display memory, and timing circuitry.

CATHODE RAY TUBE (CRT)

This device is the display element of the terminal. Information received from the control logic PWA is displayed on the CRT screen by an electron beam that is deflected at character and line increments.

HIGH-VOLTAGE TRANSFORMER

This unit develops the high voltage necessary to accelerate the electron beam from the gun elements of the CRT to its display screen.

+15-VOLT REGULATOR

This unit provides +15 V dc regulation for video circuit drive requirements.

DEFLECTION YOKE

This unit deflects the electron beam, generated from the gun element of the CRT, in the horizontal and vertical direction of the display screen.

MONITOR PWA

This logic controls the sweep of the electron beam across and up and down, the CRT screen.

REAR PANEL ASSEMBLY

This unit supplies input power to the terminal and contains the circuit breaker, connector, and ac input power cord.

†Refer to the 722-10 (CC628-A) Display Terminal Hardware Maintenance Manual for information pertaining to replaceable assemblies applicable to the CC628 display terminal.

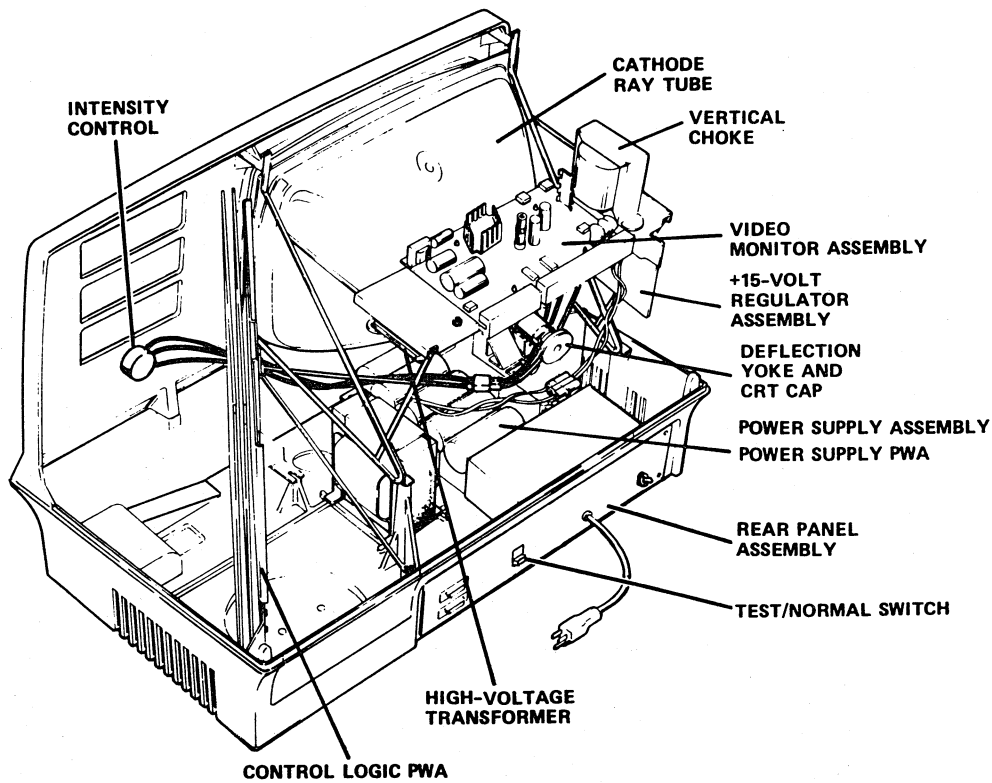

1201

Figure 4-1. CC555 Keyboard Display Terminal Subassemblies

POWER SUPPLY PWA

This PWA provides the +5 V dc, +12 V dc, and +23 V dc used by the logic and control circuits of the terminal.

VIDEO MONITOR ASSEMBLY

This unit monitors and displays electronically coded information received from the control logic.

VERTICAL CHOKE COIL

This coil is used to provide collector bias to the vertical output circuit.

KEYBOARD MODULE

This unit (figure 2-1) is used by the operator to input data to the terminal. The keyboard module contains

conventional typewriter key format and adding machine key format, along with additional control keys.

INTENSITY CONTROL POTENTIOMETER

This unit (figure 2-1) controls the raster intensity of the display. It is located on the front panel of the terminal.

POWER SUPPLY ASSEMBLY

This unit provides low voltages to the keyboard display terminal.

AUDIBLE ALARM (SONALERT)

This unit is used to produce an audible sound when an alarm condition is present.

CC555 SWITCH/JUMPER SETTINGS, NORMAL OPERATION

I/O-TTY BOARD (LOGIC)

To verify the normal operating positions of the switches on the I/O-TTY board (logic), the PWA must be removed from the chassis. This is done by first opening the cabinet access door and turning the captive latches on the cover plate one quarter turn counterclockwise. Attached to the cover plate is an extractor tool for removing the PWA.

Refer to the processor manual for the location and normal operating positions of the baud rate select switches.

After verifying that the baud rate select switches are in the normal configuration, reinsert the PWA in its assigned position. Apply firm thumb pressure at the upper and lower corners of the front of the PWA until it is fully seated within the backplane connector.

Return the extractor tool and module cover plate to the chassis. Close the front access door.

CONTROL SWITCHES (INTERNAL)

To verify the normal operating positions of the control switches internal to the console display, the top hood must be removed. This is done by first removing the two retaining screws at the rear of the display and then lifting the hood backward and upward.

BAUD RATE SWITCHES

Verify that the baud rate switches on the control logic comply with the normal operating settings illustrated in figure 4-2. These switches select the high and the low frequency rate of I/O data communication for front operator panel selection.

SPECIAL FUNCTIONAL SWITCHES

Verify that the special function switches on the PWA comply with the normal operating settings as illustrated in figure 4-2.

CC628 SWITCH/JUMPER SETTINGS, NORMAL OPERATION

I/O-TTY CONTROLLER

Refer to the CC555 display terminal I/O-TTY controller switch/jumper settings for normal operating settings applicable to the CC628 display terminal.

INTERNAL CONTROLS

Refer to the 722-10 (CC628-A) Display Terminal Reference Manual for normal operating positions of the controls internal to the CC628 display terminal.

EXTERNAL CONTROLS

The CC628 display terminal has external controls located behind the operator access door (to the right of the display screen), on and below the keyboard, and on the base of the terminal. Figure 4-3 shows the controls located behind the operator access door. Verify that the data rate select and mode select switches comply with the normal operating settings illustrated (after changing any of the mode select switches, MANUAL RELEASE must be pressed). Refer to the 722-10 (CC628-A) Display Terminal Reference Manual for instructions on how to set these switches.

Verify that the controls on and below the keyboard comply with the normal operating settings illustrated in figure 4-4. Refer to the 722-10 (CC628-A) Display Terminal Reference Manual for additional information on these controls.

Figure 4-5 shows the controls on the base of the terminal. Refer to the 722-10 (CC628-A) Display Terminal Reference Manual for information on these controls.

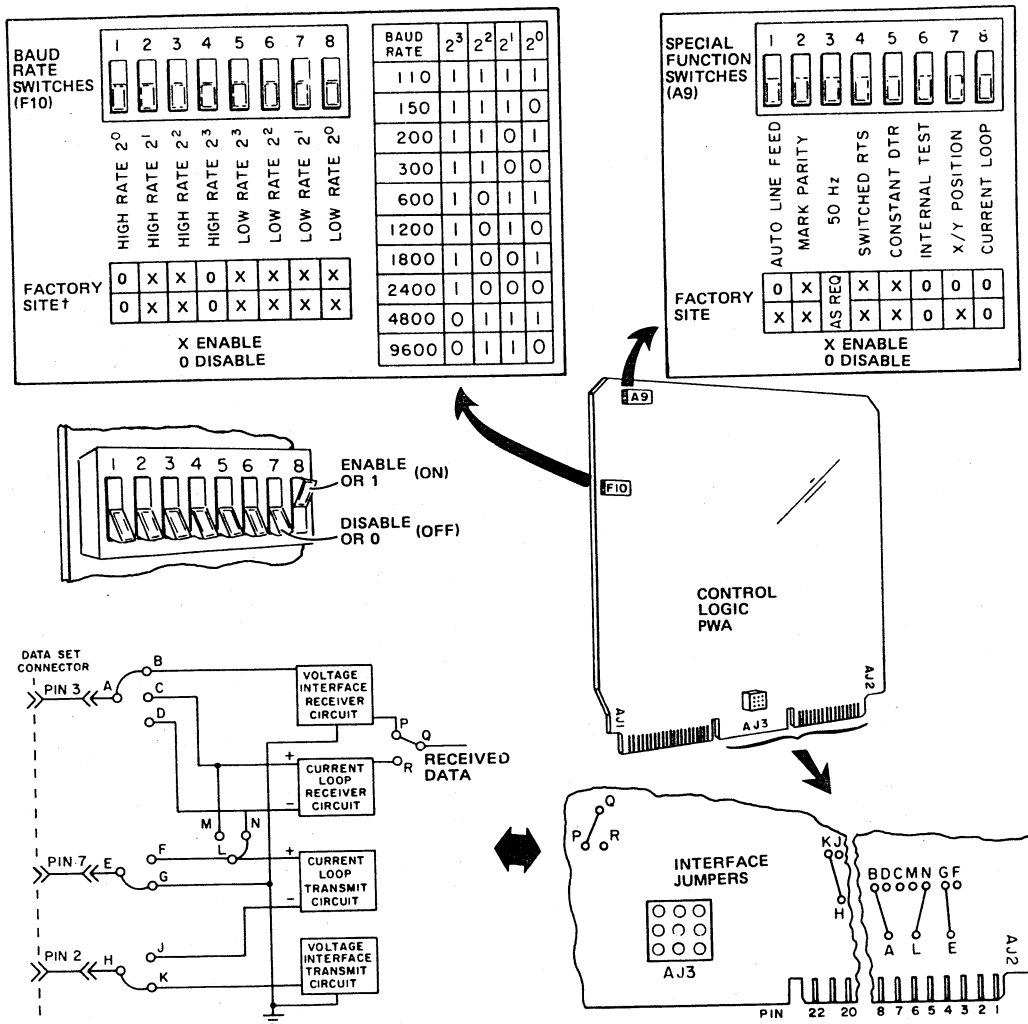

BAUD RATE	HIGH BAUD RATE SELECT				LOW BAUD RATE SELECT			
	1	2	3	4	1	2	3	4
110	ON	ON	ON	ON	ON	ON	ON	ON
150	OFF	ON	ON	ON	ON	ON	ON	OFF
200	ON	OFF	ON	ON	ON	ON	OFF	ON
300	OFF	OFF	ON	ON	ON	ON	OFF	OFF
600	ON	ON	OFF	ON	ON	OFF	ON	ON
1200	OFF	ON	OFF	ON	ON	OFF	ON	OFF
1800	ON	OFF	OFF	ON	ON	OFF	OFF	ON
2400	OFF	OFF	OFF	ON	ON	OFF	OFF	OFF
4800	ON	ON	ON	OFF	OFF	ON	ON	ON
9600††	OFF	ON	ON	OFF	OFF	ON	ON	OFF

††STANDARD SYSTEM CONFIGURATION

†SITE BLOCKS ARE MARKED TO REFLECT STANDARD SYSTEM CONFIGURATION.
1203

Figure 4-2. CC55 Keyboard Display Internal Switches and Controls

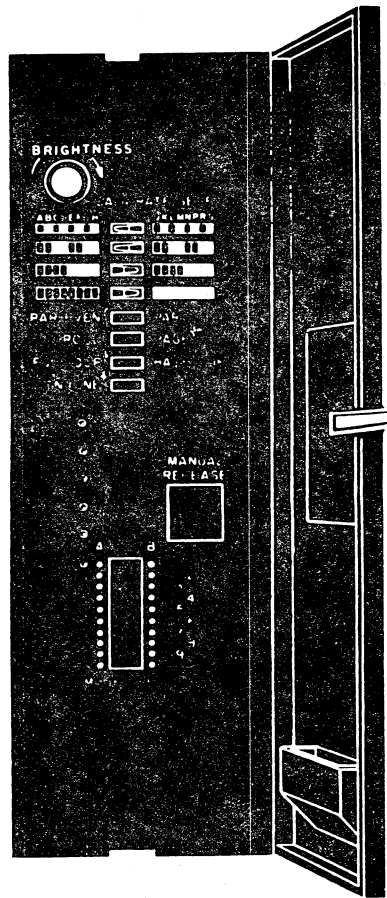

†NORMAL OPERATING POSITION
2416

DATA RATE SELECT			
A	110	J	4800
B	150	K	9600
C	200	L	19200
D	300	M	19200
E	600	N	19200
F	1200	P	19200
G	1800	R	19200
H	2400	S	19200

MODE SELECT			
SWITCH POSITION			
A		B	
1	NORMAL	1	XPARENT
2	NORMAL	2	DATA ONLY
3	PAR. ENT	3	PAR. DIS
4	1 STP. BIT	4	2 STP. BIT
5	ADVANCE	5	7524
6	NORMAL	6	AUTO LF
7	DIS BELL	7	EOL BELL
8	RTS CONST	8	RTS SW
9	DTR CONST	9	DTR SW
10	60 Hz REF	10	50 Hz REF

DECAL

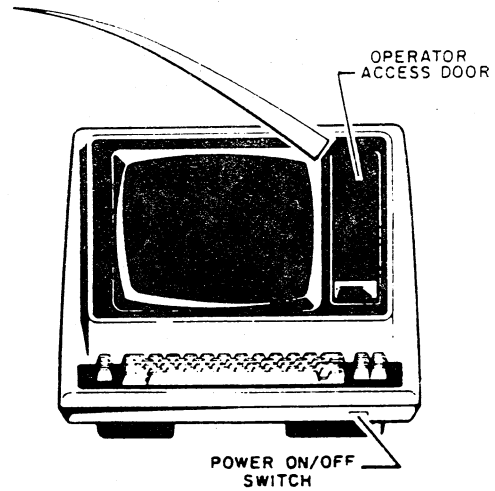
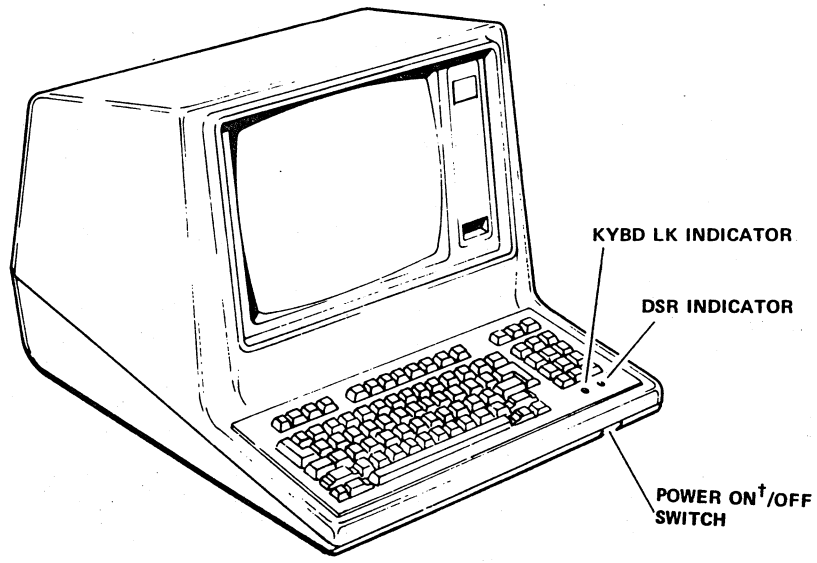

Figure 4-3. CC628 External Controls, Operator Access Door



†NORMAL OPERATING POSITION

2417

Figure 4-4. CC628 Power ON/OFF Switch and Keyboard Indicators

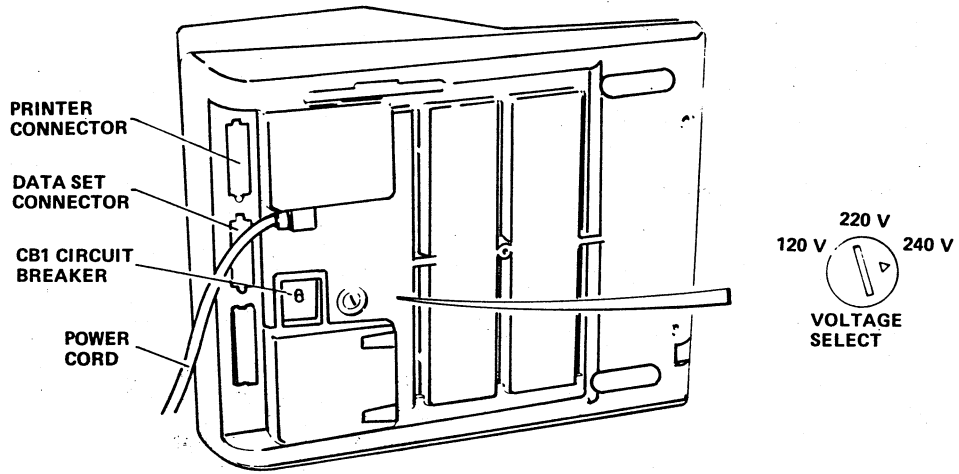

2418

Figure 4-5. CC628 Display Terminal (Bottom View)

This section contains diagrams (figures 5-1 through 5-4) illustrating the keyboard display terminal subsystem

interconnections and the subsystem connection to the processor.†

†For diagrams applicable to the CC628 display terminal refer to the 722-10 (CC628-A) Display Terminal Hardware Maintenance Manual.

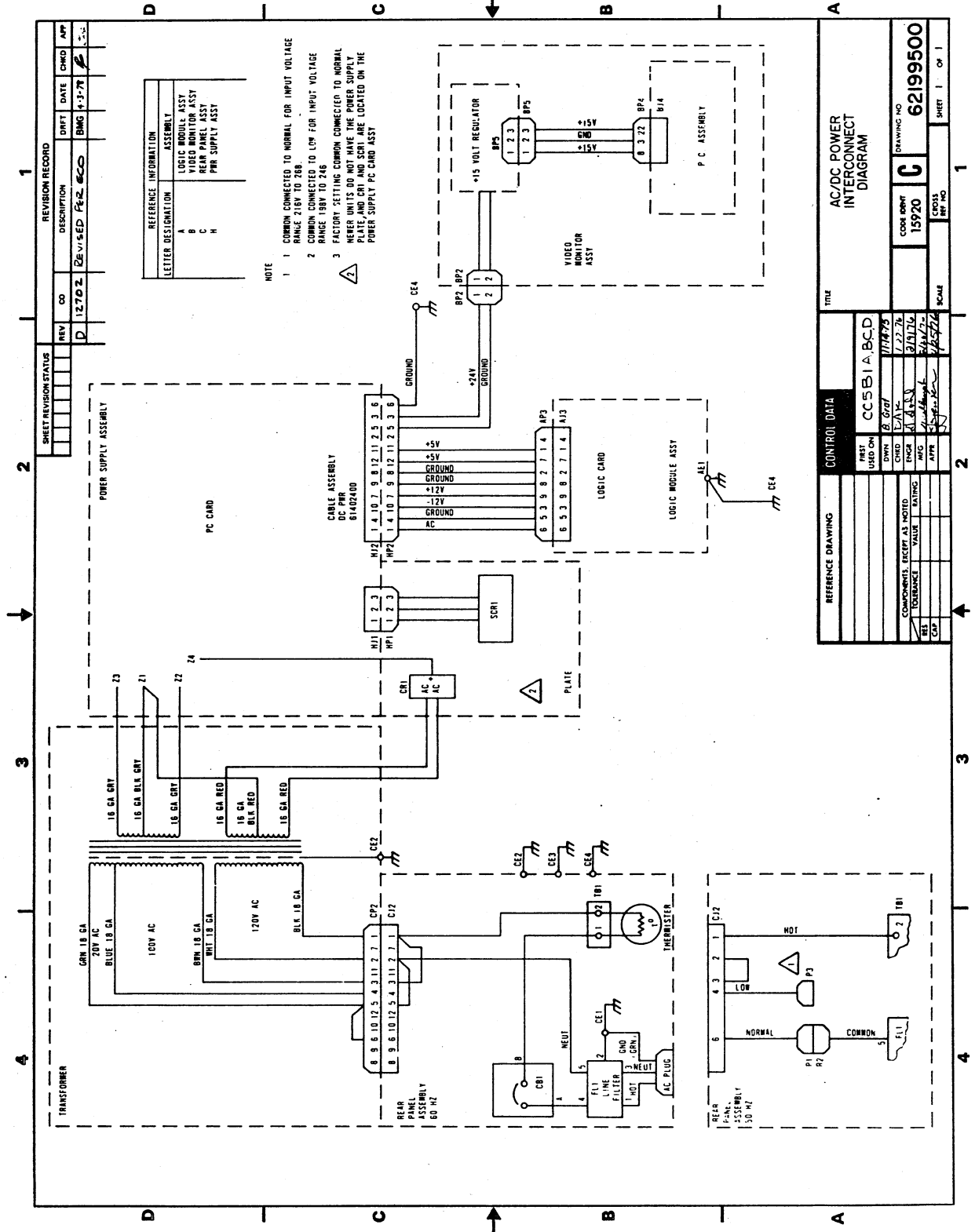
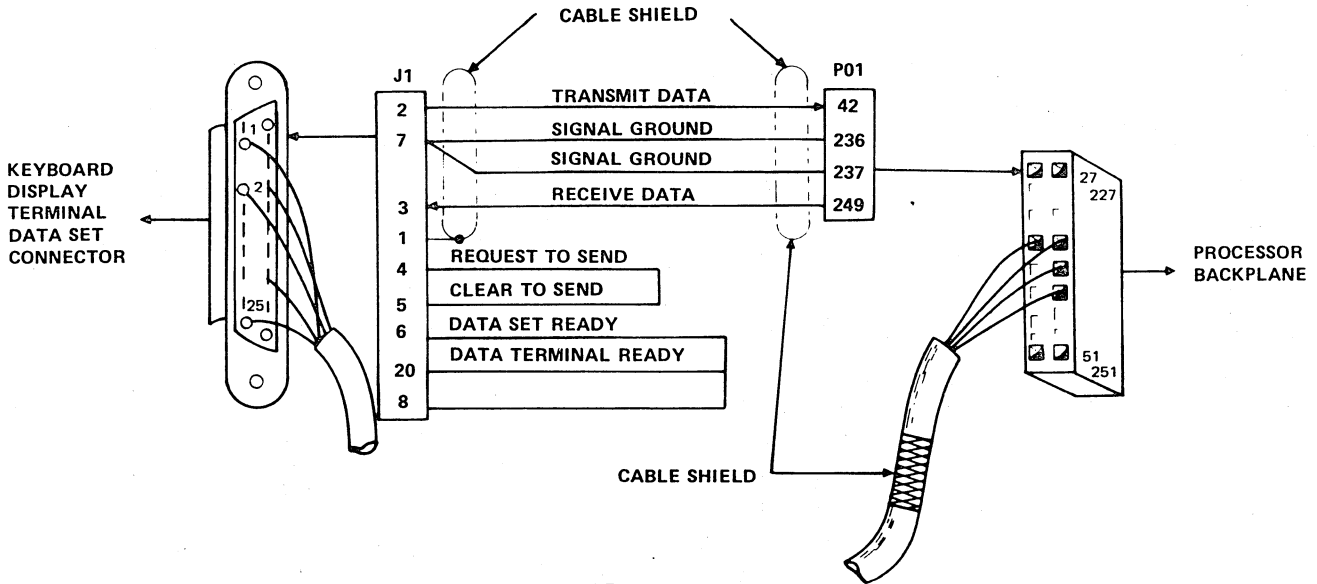

Figure 5-2. Ac/Dc Power Interconnect Diagram



LENGTH TABLE

LENGTH	PART NO.
6 FT (1.83 M)†	96729500
10 FT (3.05 M)	96729501
15 FT (4.57 M)†	96729502

†AVAILABLE ON SPECIAL ORDER ONLY
1204

Figure 5-3. Keyboard Display to I/O-TTY Controller Interface Cable

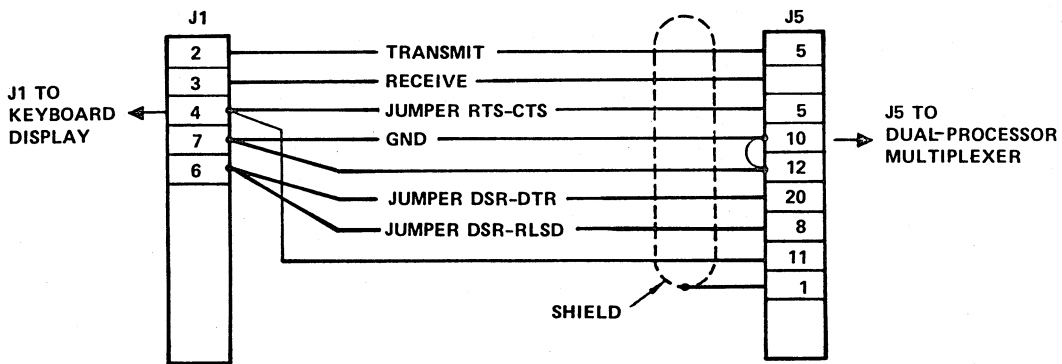

LENGTH	PART NO.
15 FT (4.57 M)	967448876

1205

Figure 5-4. CYBER 18 Cable - Keyboard Display to Panel Multiplexer

This section contains a diagnostic decision logic table (DDLT) and corrective action procedures applicable to the keyboard display terminal subsystem. The DDLT contains troubleshooting procedures that provide fault isolation of equipment malfunctions. The corrective action procedures provide for step-by-step removal and replacement of the defective subassemblies.

The DDLT procedures consist of offline test sequences and/or the operational diagnostic system (ODS) tests contained on diskettes or cassette tapes. The ODS tests are used in conjunction with the DDLTs applicable to the subsystem. All ODS tests for a subsystem must use ODS programs contained on the same test medium, either diskettes or cassette tapes. Do not intermix test media during a system checkout.

MAINTENANCE AIDS

Operational diagnostic system (ODS) programs required to test the keyboard display terminal subsystem are:

LDCHK
MPINS
LIAT1
CLACD

For part numbers of the ODS test programs, refer to the overview manual listed in the preface.

MAINTENANCE EQUIPMENT REQUIRED

The following test equipment is required:

- Multimeter – 0 V dc through 500 V dc, accuracy 2 percent minimum, 20K ohm/V; 0 V ac through 250 V ac, accuracy 3 percent minimum
- Wire – 12-inch heavy insulated wire (16 AWG) with insulation stripped approximately 1/2 inch on each end.
- Safety goggles – One set
- Heavy gloves – One pair

If higher level maintenance is required, the following additional maintenance tools are needed:

- Oscilloscope – Dual trace, dc to 10 MHz minimum, calibrated trigger sweep (Tektronics model 546).

DESCRIPTION OF DIAGNOSTIC DECISION LOGIC TABLES

The DDLTs identify and isolate equipment malfunctions in the replaceable assemblies. The DDLT analyzes a situation down to specific conditions and then directs the customer engineer to those actions that will correct the situation,

with the most likely action listed first. The table is arranged in five sections: assumptions, conditions, responses, actions, and sequence of actions (see the DDLT example in figure 6-1).

ASSUMPTIONS

The upper section of the DDLT contains the prerequisites for the specific tests to be performed. The DDLT is valid only if all assumptions are true.

CONDITIONS

The center left section of the DDLT contains the conditions or tests to be made. They are in the form of questions that can be answered yes or no.

RESPONSES

The center right section of the DDLT contains the response to the question asked in the Conditions section. Note that each condition, or question, can be answered with a yes (Y) or a no (N). The example chosen for figure 6-1 has 10 unique situations, numbered from 1 to 10, left to right. The shaded area in the example shows the conditions that define situation 9. That is, the POWER ON indicator does not illuminate, all other indicators do not illuminate when the READ CHECK indicator/switch is pressed, and no single indicator illuminates.

The first condition should be examined for a yes or no response. The applicable response directs the operator to the next condition in the column until all conditions in that column have been analyzed. In figure 6-1, column 1 identifies an everything-is-normal situation for the tests made. Therefore, the Actions section in the lower left of the table directs the customer engineer: Go to sheet 2 of this table. The customer engineer then goes to sheet 2 of the table and does not waste time with further examination of sheet 1.

ACTIONS

The lower left quadrant lists actions to correct a situation.

SEQUENCE OF ACTIONS

The lower right section lists the sequence of the actions required to correct a situation, with each succeeding action being performed only if a previous action failed to correct the condition under test. The sequential numbering of actions reflects the probability of the corresponding action correcting the problem, with the most likely listed first. An X indicates that no sequence of actions is necessary, but the single action listed must be performed. Both actions and conditions may refer to other specific procedures to follow (for example, when checking and adjusting the power supply voltages). The customer engineer must exit from the table to perform the other procedure and then return to the same

TABLE 6-51. CARD READER DDLT

Power On	Sheet 1 of 6									
<p>ASSUMPTIONS:</p> <ol style="list-style-type: none"> If card reader is load device, go to sheet 2 of this table. Card reader power cord is connected to ac outlet. Power is on (procedure 1). Ensure card reader is not ready by pressing RESET. <p style="text-align: center;">①</p>										
<p>CONDITIONS:</p> <ol style="list-style-type: none"> Is POWER ON indicator on card reader illuminated/ Press READ CHECK switch/indicator. Do all other indicators illuminate? Do any indicators illuminate? Press and release RESET switch/indicator. Does RESET indicator illuminate? When RESET switch/indicator is pressed, do stacker springs and/or card drum turn? Did motor power come up and then drop within 10 to 30 seconds after releasing RESET switch/indicator? 	1	2	3	4	5	6	7	8	9	10
	Y						N			
	Y			N			Y	N		
					Y	N		Y	N	
	Y		N							③
	Y	N								
	Y	N								
<p>ACTIONS:</p> <ol style="list-style-type: none"> Go to sheet 2 of this table. Check that toggle switch S1 (rear panel) is up. Check that removable power cord is connected securely to card reader. Check fuses (rear panel) and ac power. Check switch board and associated cabling (procedure 9). Replace if required (procedure 10). Check +17-volt power supply (procedure 6). Check for +17 vdc between ground and control board connector P2, pins 2 and 3, and between ground and switch board connector, pins 2 and 3 (two pins joined by foil). Check cable between control board and switch board. Replace lamp in failing indicator (procedure 9). 	X									
										⑤
										④
									2	
									3	
				3	2	2	2		4	
								1		
								2		
								3		
							1			

RESPONSES

SEQUENCE OF ACTIONS

NOTE: ARROWS AND CIRCLED NUMBERS INDICATE SEQUENTIAL FLOW OF ANALYSIS PROCEDURE.

Figure 6-1. Example of a Diagnostic Decision Logic Table

point in the table if the fault still persists. The same is true if the customer engineer exits to another table or sheet of the same table but does not find the fault, and the action that called for the exit is not the last action in the sequence.

The customer engineer must return to his original DDLT exit point and continue testing from there.

After taking corrective action, the customer engineer should rerun the DDLT starting at sheet 1 to make sure that the fault has been corrected.

USER NOTES

The following are precautions the customer engineer should keep in mind while performing diagnostic testing:

- If the DDLT's are run using a CC628 display terminal, observe the following functional changes when entering information through the keyboard:

<u>To Enter</u>	<u>Press Simultaneously</u>
ETX	CONTROL and C
CLEAR	CONTROL and X
ENTER-	CONTROL and /
ENTER+	CONTROL and [
LINE FEED	SHIFT and ↓
CARRIAGE RETURN	CR or NEW LINE
RESET	SHIFT and HOME
RUBOUT	DEL
BEL	CONTROL and G

- After any power to the computer is turned on or off, the computer should be master cleared.
- Power to the peripherals should be turned off before power to the computer is turned off.
- Printed wiring assemblies may be removed from, or installed in, the processor with the power on.
- Do not press any key on the console display while diagnostic media is being loaded.

Whenever the ESC key on the console display is pressed, the computer is placed into panel mode. This prevents further messages from being displayed on the screen. To a user it appears that the system is hung up. If the ESC key is accidentally pressed, the condition can be rectified by pressing the @ character on the keyboard.

The DDLTs presume all operator inputs are entered correctly. Any incorrect entry may cause the DDLT to direct an incorrect action. Hence, if any doubt exists about the accuracy of the operator entry, always repeat the sequence of DDLT steps that led up to an action before taking further actions.

If any characters are accidentally pressed on the keyboard, the KEYBOARD LOCK and ALERT lights on the display illuminate. If this occurs, the BREAK key must be pressed to continue.

ODS SOFTWARE

For additional information regarding the use of the ODS diagnostic tests, refer to the Operational Diagnostic System Reference Manual. Excerpts from this manual are listed below.

If an erroneous test entry is made and executed during a level II[†] test, perform the following:

1. Simultaneously press the CONTROL and BEL keys on the keyboard.

2. Type in:

ODS,ABRT,xxxxx

where xxxxx is the ODS test mnemonic.

3. Press the CARRIAGE RETURN key. The remainder of the test loads.
4. Reload the test and return to the DDLT (sheet 1) of the device under test.

NOTE

If step 2 above cannot be performed, restart the Loadcheck DDLT (in the processor manual).

For error code typeouts not listed in the DDLTs, refer to the following:

<u>Typeout</u>	<u>Description</u>
GHOST INTERRUPT LINES xxxx	Level I tests. An unexpected interrupt was received. xxxx = A bit mask indicating which line was interrupted
MI	Level II tests. A manual interrupt (CONTROL and BEL) has been received, and the system is waiting for the ODS level II command.
MI INPUT ERROR	Level II tests. The command did not begin with ODS. Press CONTROL and BEL and then re-enter the command.
ODS BUSY	Level II tests. ODS is currently processing the last command entered. Re-enter the command.
ODS ERROR xx	Level II tests. An operator command input error occurred during loading of the test or while the test was not processing. Re-enter the command correctly. xx = 01 Invalid command mnemonic 02 Third field must be entered 03 Invalid test availability 04 Command is not valid for the master parameter list 05 Too many field inputs for the command

[†] Level II tests are subsystem diagnostic programs that run under the ODS monitor and are loaded by the Level II Monitor DDLT contained in the processor manual.

Typeout

Description

Typeout

Description

- 06 Nonhexadecimal input
- 07 Invalid parameter
- 08 Invalid parameter index
- 09 Test not currently suspended
- 10 No change in parameter data input
- 11 Available memory has been exceeded
- 12 Test not found on library unit

- PE
- PF
- PW

- Level II tests. A macro MOS parity fault interrupt has occurred. Reload the system.
- Level II tests. A protect fault interrupt has occurred. Reload the system.
- Level II tests. A power failure protect interrupt has occurred. Reload the system.

OV

Level II tests. An overflow of the monitor's usable memory has occurred. Reload the system.

DIAGNOSTIC DECISION LOGIC TABLE

Table 6-1 is the DDLT for the subsystem. The removal/replacement and testing procedures immediately follow the DDLT.

TABLE 6-1. LIAT1: KEYBOARD DISPLAY TERMINAL DIAGNOSTIC DDLT

Diagnostic Test of CC555 and CC628 when Connected to I/O-TTY Logic		Sheet 1 of 14		
ASSUMPTIONS:				
1. The Loadcheck and Instruction Test DDLTs in the processor manual have been successfully completed.				
2. After xxxxx? is displayed, enter the following at the keyboard (if xxxxx is not displayed, go to the Loader Fault DDLT in the processor manual):				
Type LIAT1 Press CARRIAGE RETURN The diagnostic stops with the message LIAT1 SUSPENDED BOT displayed. Type GO Press CARRIAGE RETURN				
3. Observe the screen for the following conditions.				
CONDITIONS:		1	2	3
1.	Is LIAT1 EXECUTING displayed?	Y	N	
2.	Is RUN indicator illuminated?		N	Y
ACTIONS:				
1.	Go to sheet 2 of this table.	X		
2.	Go to the Loader Fault DDLT in the processor manual.		X	
3.	Go to the System Fault DDLT in the processor manual.			X

TABLE 6-1. LIAT1: KEYBOARD TERMINAL DIAGNOSTIC DDLT (Contd)

Diagnostic Test of CC555 and CC628 when Connected to I/O-TTY Logic		Sheet 2 of 14		
ASSUMPTIONS:				
Observe the screen for any of the following conditions.				
CONDITIONS:		1	2	3
1.	Is LIAT1 SUSPENDED ENDS displayed?	Y	N	
2.	Is there an action code?		Y	N
ACTIONS:				
1.	Go to sheet 3 of this table.	X		
2.	If testing a CC555, go to table CRT1 in the Keyboard Display Terminal Hardware Maintenance Manual and perform the specified tests and checks. If testing a CC628, go to the 722-10 (CC628-A) Display Terminal Hardware Maintenance Manual.		X	
3.	Call next level of support.			X

TABLE 6-1. LIAT1: KEYBOARD DISPLAY TERMINAL DIAGNOSTIC DDLT (Contd)

Diagnostic Test of CC555 and CC628 when Connected to I/O-TTY Logic						Sheet 3 of 14						
ASSUMPTIONS:												
1. Conditions 1 through 6 below are understood before test execution. 2. The following is entered at the keyboard: Type GO Press CARRIAGE RETURN 3. Observe the keyboard display for any of the following conditions.												
CONDITIONS:						1	2	3	4	5	6	7
1. Does sonic alarm sound three times?						Y						N
2. Does the screen clear?						Y					N	
3. Does the cursor move from position 0 to position 80 and back across the screen several times?						Y				N		
4. Are the following test patterns displayed in order (see sheet 4 of this table)?						Y			N			
5. Does the screen clear?						Y		N				
6. Is LIAT1 SUSPENDED ENDS displayed?						Y	N					
ACTIONS:												
1. Go to sheet 5 of this table.						X						
2. If testing a CC555, go to table CRT1 in the Keyboard Display Terminal Hardware Maintenance Manual and perform the specified tests and checks. If testing a CC628, go to the 722-10 (CC628-A) Display Terminal Hardware Maintenance Manual.							1	1	1	3	1	2
3. Replace I/O-TTY logic (refer to the board (logic) replacement procedure in the processor manual).										1		1
4. Replace SMI logic (refer to the board (logic) replacement procedure in the processor manual).										2		
5. Call next level of support.							2	2	2	4	2	3

TABLE 6-1. LIAT1: KEYBOARD DISPLAY TERMINAL DIAGNOSTIC DDLT (Contd)

Diagnostic Test of CC555 and CC628 when Connected to I/O-TTY Logic		Sheet 5 of 14		
ASSUMPTIONS:				
1. Conditions 1 and 2 are read to prepare for test execution.				
2. The following is entered at the keyboard:				
Type GO				
Press CARRIAGE RETURN				
3. Observe the screen for any of the following conditions.				
CONDITIONS:		1	2	3
1. Are the test patterns on sheet 6 of this table displayed in order?		Y		N
2. Is LIAT1 SUSPENDED ENDS displayed?		Y	N	
ACTIONS:				
1. Go to sheet 7 of this table.		X		
2. If testing a CC555, go to table CRT1 in the Keyboard Display Hardware Maintenance Manual and perform the specified tests and checks. If testing a CC628 go to the 722-10 (CC628-A) Display Terminal Hardware Maintenance Manual.			1	1
3. Call next level of support.			2	2

TABLE 6-1. LIAT1: KEYBOARD DISPLAY TERMINAL DIAGNOSTIC DDLT (Contd)

Diagnostic Test of CC555 and CC628 when Connected to I/O-TTY Logic		Sheet 7 of 14		
ASSUMPTIONS:				
1. The following is entered at the keyboard: Type GO Press CARRIAGE RETURN				
2. Observe the screen for test pattern 10 (sheet 8) and for any of the following conditions.				
CONDITIONS:		1	2	3
1.	Is LIAT1 SUSPENDED ENDS displayed?	Y	N	
2.	Is there an action code?		Y	N
ACTIONS:				
1.	Go to sheet 9 of this table.	X		
2.	If testing a CC555, go to table CRT1 in the Keyboard Display Terminal Hardware Maintenance Manual and perform the specified tests and checks. If testing a CC628, go to the 722-10 (CC628-A) Display Terminal Hardware Maintenance Manual.		1	
3.	Call next level of support.		2	X

TABLE 6-1. LIAT1: KEYBOARD DISPLAY TERMINAL DIAGNOSTIC DDLT (Contd)

Diagnostic Test of CC555 and CC628 when Connected to I/O-TTY Logic

Sheet 8 of 14

```

      1
     2 2
    3 3
   4 4
  5 5
 6 6
7 7
8 8
9 9
0 0
1 1
2 2
3 3
4 4
5 5
6 6
7 7
8 8
9 9
0 0
1 1
2 2
3 3
4 4
5 5
6 6
7 7
8 8
9 9
0 0
1 1
2 2
3 3
4 4

```

Test Pattern 10

TABLE 6-1. LIAT1: KEYBOARD DISPLAY TERMINAL DIAGNOSTIC DDLT (Contd)

Diagnostic Test of CC555 and CC628 when Connected to I/O-TTY Logic		Sheet 9 of 14		
ASSUMPTIONS:				
1. The following is entered at the keyboard: Type GO Press CARRIAGE RETURN				
2. Observe the screen for any of the following conditions.				
CONDITIONS:		1	2	3
1. Is LIAT1 SUSPENDED ENDS displayed?		Y	N	
2. Is there an action code?			Y	N
ACTIONS:				
1. Go to sheet 10 of this table.		X		
2. If testing a CC555, go to table CRT1 in the Keyboard Display Terminal Hardware Maintenance Manual and perform the specified tests and checks. If testing a CC628 go to the 722-10 (CC628-A) Display Terminal Hardware Maintenance Manual.			1	
3. Call next level of support.			2	X

TABLE 6-1. LIAT1: KEYBOARD DISPLAY TERMINAL DIAGNOSTIC DDLT (Contd)

Diagnostic Test of CC555 and CC628 when Connected to I/O-TTY Logic		Sheet 10 of 14				
ASSUMPTIONS:						
1. The following is entered at the keyboard: Type GO Press CARRIAGE RETURN						
2. When requested by the display, 1234567890 is typed in on the keyboard.						
3. Observe the screen for any of the following conditions.						
CONDITIONS:				1	2	3
1. Is LIAT1 SUSPENDED ENDS displayed?				Y	N	
2. Is there an action code?					Y	N
ACTIONS:						
1. Go to sheet 11 of this table.				X		
2. If testing a CC555, go to table CRT1 in the Keyboard Display Terminal Hardware Maintenance Manual and perform the specified tests and checks. If testing a CC628 go to the 722-10 (CC628-A) Display Terminal Hardware Maintenance Manual.					1	
3. Call next level of support.					2	X

TABLE 6-1. LIAT1: KEYBOARD DISPLAY TERMINAL DIAGNOSTIC DDLT (Contd)

Diagnostic Test of CC555 and CC628 when Connected to I/O-TTY Logic		Sheet 11 of 14			
ASSUMPTIONS:					
1. The following is entered at the keyboard: Type GO Press CARRIAGE RETURN					
2. When requested by the display, the following is entered at the keyboard: Type ABCDEFGHIJKLMNOPQRSTUVWXYZ1234567890 Press CARRIAGE RETURN					
3. Observe the screen for any of the following conditions.					
CONDITIONS:		1	2	3	4
1. Is LIAT1 SUSPENDED ENDS displayed?		Y		N	
2. Does the display repeat that data exactly below the input data?		Y	N		
3. Is there an action code?				Y	N
ACTIONS:					
1. Go to sheet 12 of this table.		X			
2. If testing a CC555, go to table CRT1 in the Keyboard Display Terminal Hardware Maintenance Manual and perform the specified tests and checks. If testing a CC628, go to the 722-10 (CC628-A) Display Terminal Hardware Maintenance Manual.			2		
3. Replace I/O-TTY logic (refer to the board (logic) replacement procedure in the processor manual).			1		1
4. Replace SMI logic (refer to the board (logic) replacement procedure in the processor manual).					2
5. Go to sheet 14 of this table.				X	
6. Call next level of support.			3		3

TABLE 6-1. LIAT1: KEYBOARD DISPLAY TERMINAL DIAGNOSTIC DDLT (Contd)

Diagnostic Test of CC555 and CC628 when Connected to I/O-TTY Logic		Sheet 12 of 14				
ASSUMPTIONS:						
1. The following is entered at the keyboard: Type GO Press CARRIAGE RETURN						
2. Entries are made as directed by the display. [†]						
3. Observe the screen for any of the following conditions.						
CONDITIONS:				1	2	3
1. Is LIAT1 SUSPENDED ENDS displayed?				Y	N	
2. Is there an action code?					Y	N
ACTIONS:						
1. Go to sheet 13 of this table.				X		
2. If testing a CC555, go to table CRT1 in the Keyboard Display Terminal Hardware Maintenance Manual and perform the specified tests and checks. If testing a CC628 go to the 722-10 (CC628-A) Display Terminal Hardware Maintenance Manual					1	
3. Call next level of support.					2	X

[†] For CC628 only: after every change of the parity switch, the manual release button must be pressed before entering the alphanumeric character.

TABLE 6-1. LIAT1: KEYBOARD DISPLAY TERMINAL DIAGNOSTIC DDLT (Contd)

Diagnostic Test of CC555 and CC628 when Connected to I/O-TTY Logic		Sheet 13 of 14		
ASSUMPTIONS:				
1. The following is entered at the keyboard: Type GO Press CARRIAGE RETURN				
2. Entries and switch changes are made as directed by display.				
3. Observe the screen for any of the following conditions.				
CONDITIONS:		1	2	3
1. Is LIAT1 SUSPENDED ENDS displayed?		Y	N	
2. Is there an action code?			Y	N
ACTIONS:				
1. At the keyboard: Type GO Press CARRIAGE RETURN		1		
2. If testing a CC555, go to table CRT1 in the Keyboard Display Terminal Hardware Maintenance Manual and perform the specified tests and checks. If testing a CC628, go to the 722-10 (CC628-A) Display Terminal Hardware Maintenance Manual.			1	
3. Call next level of support.			2	X
4. Set switches to their original positions (see figure 4-2 and section 4 of the processor manual for standard system configurations).		2		

TABLE 6-1. LIAT1: KEYBOARD DISPLAY TERMINAL DIAGNOSTIC DDLT (Contd)

Diagnostic Test of CC555 and CC628 when Connected to I/O-TTY Logic		Sheet 14 of 14						
ASSUMPTIONS:								
1. An action code is displayed on the display screen. 2. Observe keyboard display for the following conditions.								
CONDITIONS:		1	2	3	4	5	6	7
Does the screen display:								
1.	0711 or 0731 or 0721 or 0722 or 0732	Y	N					
2.	0733		Y	N				
3.	0741			Y	N			
4.	0742				Y	N		
5.	0750					Y	N	
6.	0751						Y	N
ACTIONS:								
1.	If testing a CC555, go to table CRT1 in the Keyboard Display Terminal Hardware Maintenance Manual and perform the specified tests and checks. If testing a CC628, go to the 722-10 (CC628-A) Display Terminal Hardware Maintenance Manual.	1	1	1	1	1	1	
2.	Replace I/O logic (refer to the board (logic) replacement procedure in the processor manual).	2	3	2		2	2	
3.	Replace SMI logic (refer to the board (logic) replacement procedure in the processor manual).		2			3		
4.	Call next level of support.	3	4	3	2	4	3	X

PROCEDURES

Refer to the Keyboard Display Terminal Hardware Maintenance Manual for all procedures that relate to

the CC555 keyboard display terminal. Refer to the 722-10 (CC628-A) Display Terminal Hardware Maintenance Manual for all procedures that relate to the CC628 display terminal.



PARTS DATA

Table 7-1 lists the replaceable assemblies and their part numbers for the keyboard display terminal subsystem.

TABLE 7-1. PARTS DATA FOR KEYBOARD DISPLAY TERMINAL

Assembly	Equipment Number	Spare Part	Part Number
Keyboard Display Terminal	CC555-A	Printed wiring assembly, logic module	90460698
		Printed wiring assembly, monitor	90460619
		Cathode ray tube	51907300
		Transformer, high-voltage	61407417
		15-volt regulator	15130504
		Rear panel assembly	61407635
		Printed wiring assembly, bulk power supply	90421700
		Switch, test/normal	51781602
		Vertical choke coil	61407419
		Keyboard module	51915401
		Deflection yoke	61407418
		Potentiometer, intensity control	51899042
		Audible alarm	51908901
Power supply assembly	61407447		
Display Terminal	CC628-A or CC628-B	Card assembly (9BTD) main logic	90446159 or 90446308 [†]
		Card assembly (9BST) switch panel	90446156
		Monitor circuit card	66312052
		Keyboard	51940698 or 51940701 or 51941197 [†]
		I/O-TTY Controller	CW212-A
		Cable, interface	96729501

[†] Preferred part for CC628-A; only valid part for CC628-B.

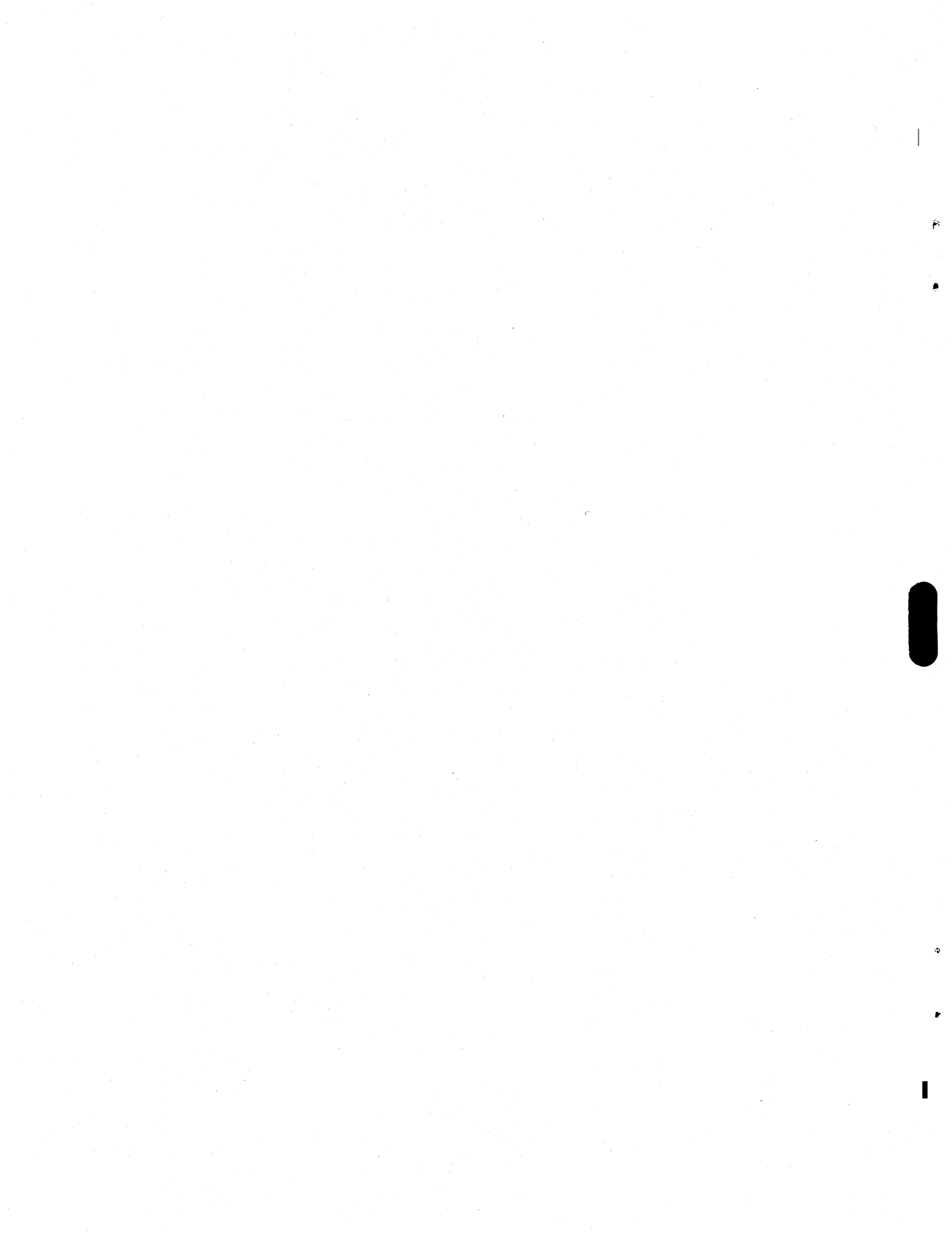

COMMENT SHEET

MANUAL TITLE CDC® CC555, CC628, CW212 Keyboard Display Terminal Subsystem

Field Repair Guide

PUBLICATION NO. 60475022

REVISION D

FROM NAME: _____

BUSINESS

ADDRESS: _____

COMMENTS: This form is not intended to be used as an order blank. Your evaluation of this manual will be welcomed by Control Data Corporation. Any errors, suggested additions or deletions, or general comments may be made below. Please include page number.

Please Reply

No Reply Necessary

CUT ALONG LINE

STAPLE

STAPLE

FOLD

FOLD



NO POSTAGE
NECESSARY
IF MAILED
IN THE
UNITED STATES

BUSINESS REPLY MAIL
FIRST CLASS PERMIT NO. 8241 MINNEAPOLIS, MINN.

POSTAGE WILL BE PAID BY

CONTROL DATA CORPORATION
PUBLICATIONS AND GRAPHICS DIVISION
4455 EASTGATE MALL
LA JOLLA, CALIFORNIA 92037



CUT ALONG LINE

FOLD

FOLD

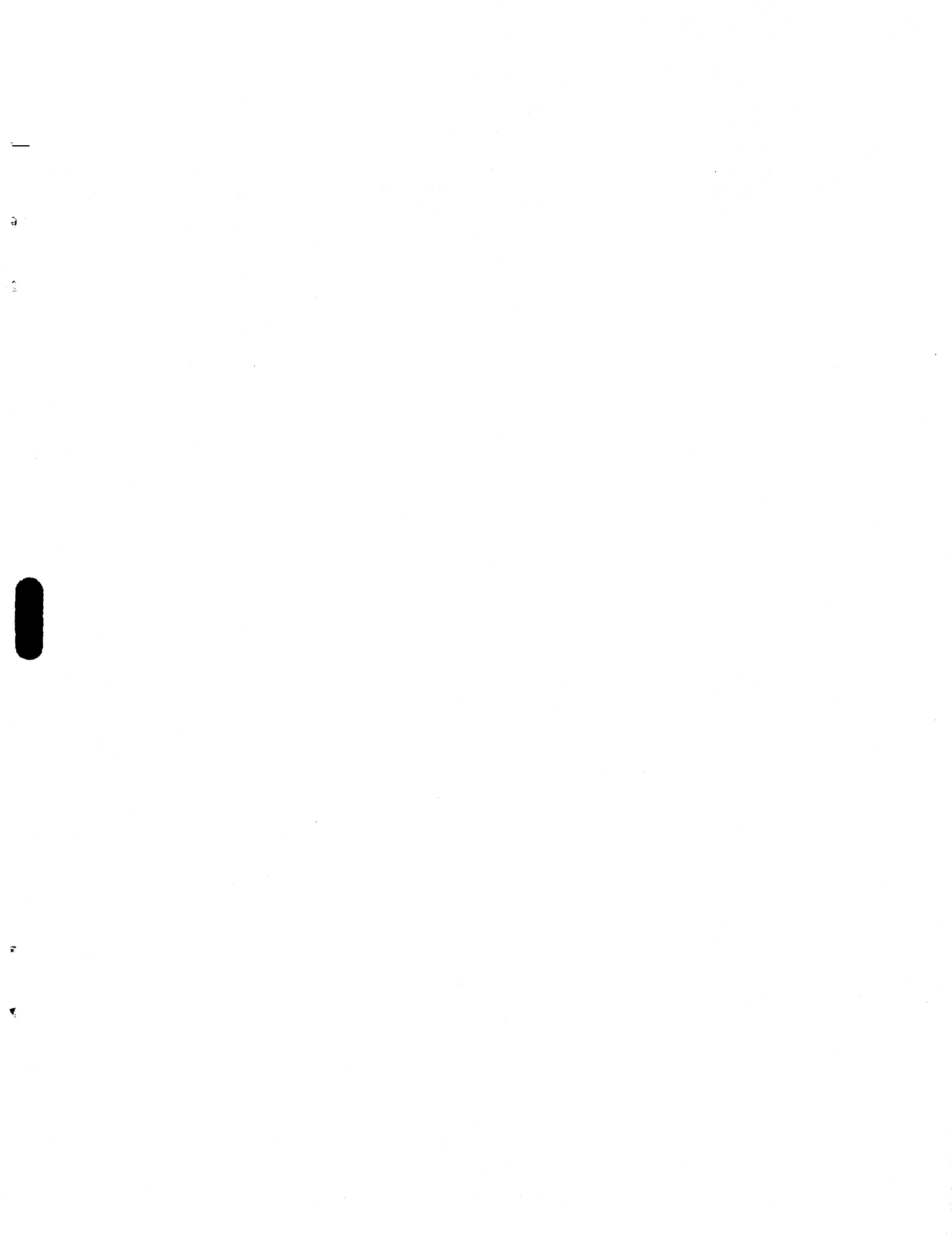

CORPORATE HEADQUARTERS, P.O. BOX 0, MINNEAPOLIS, MINN. 55440
SALES OFFICES AND SERVICE CENTERS IN MAJOR CITIES THROUGHOUT THE WORLD

LITHO IN U.S.A.



CONTROL DATA CORPORATION